

LX6/7 (Liverpool) BLOCK DIAGRAM

LAYER 1 : TOP
LAYER 2 : SGND
LAYER 3 : IN1(High)
LAYER 4 : IN2(Low)
LAYER 5 : SVCC
LAYER 6 : BOT

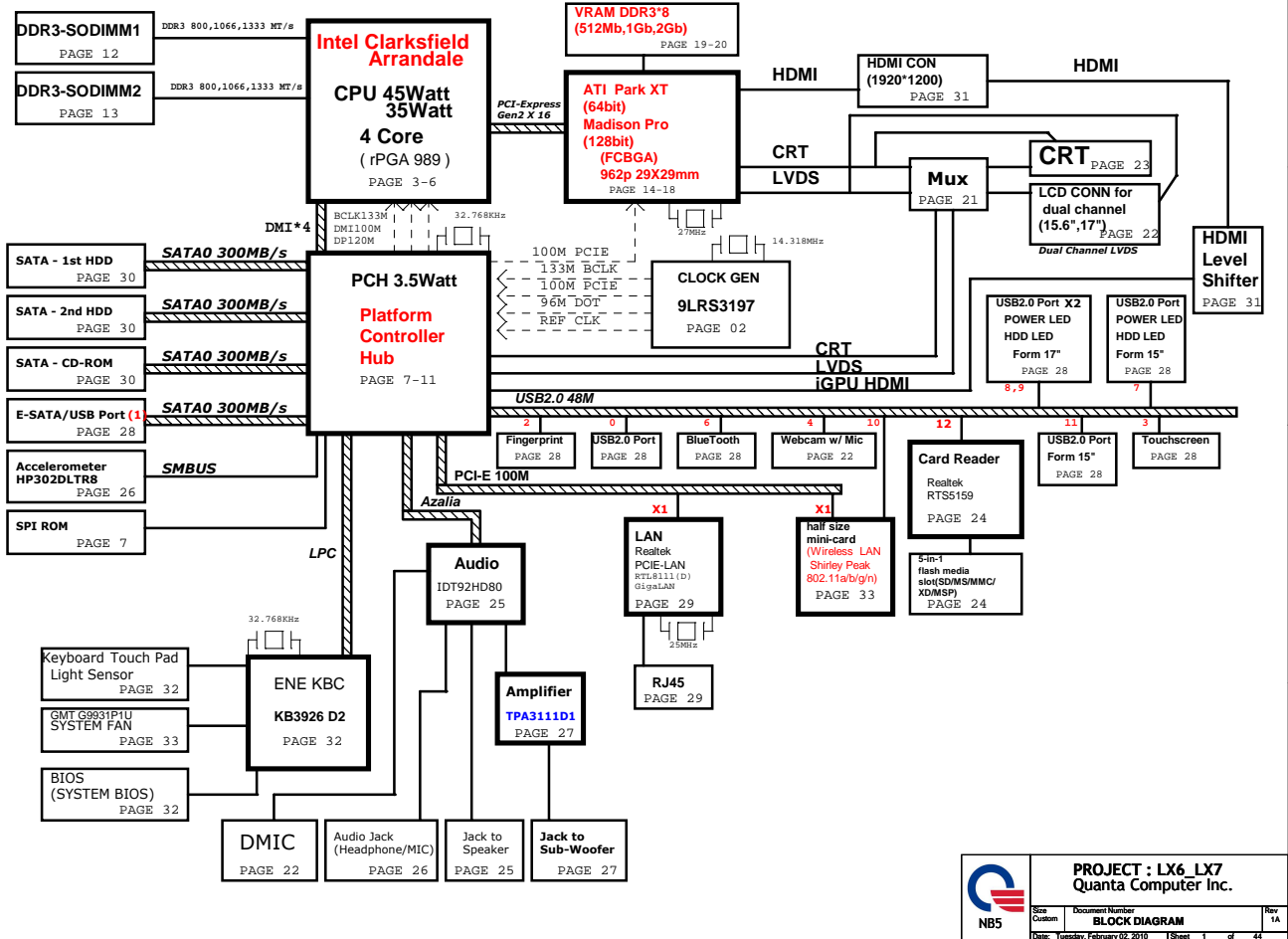

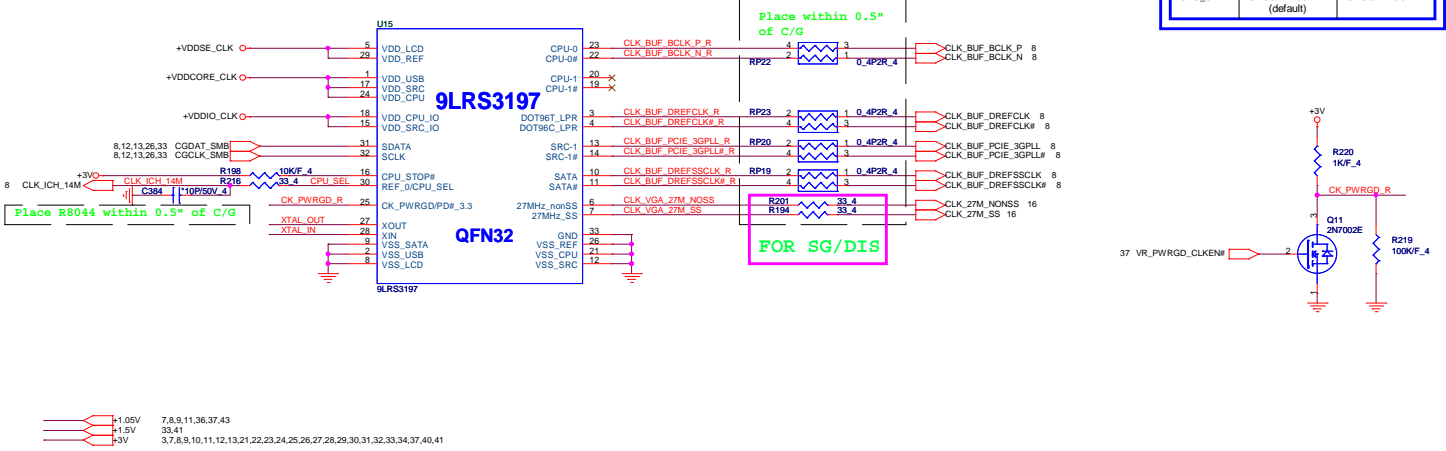
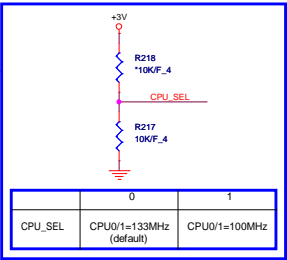
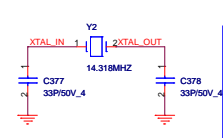
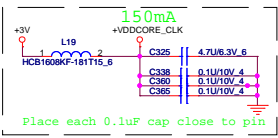
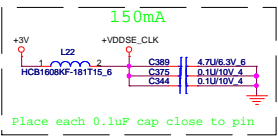
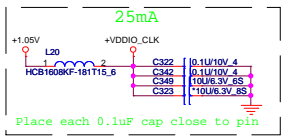

HOLE

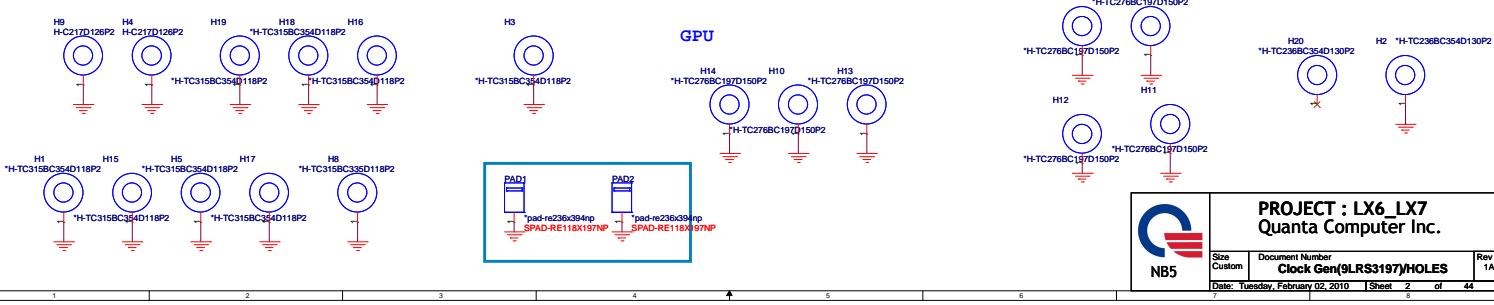

DIS	NA	0 ohm
Ra	0 ohm	NA
Rb	0 ohm	NA
Rc	0 ohm	NA

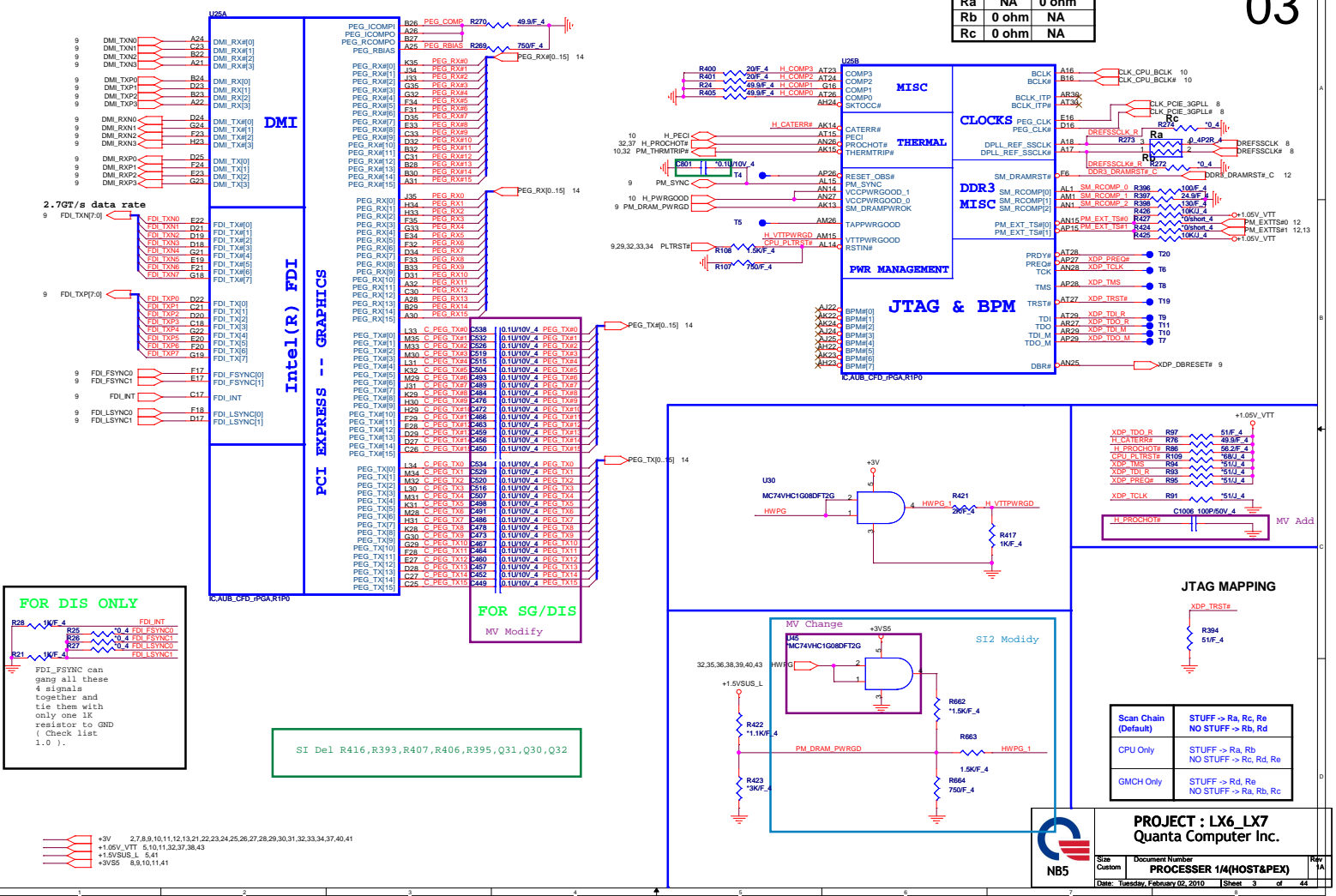

FOR DIS ONLY

R28 1K6F_4
R25 10K_4
R26 10K_4
R27 10K_4
R21 10K_4

FDI_FSYNC can gang all these 4 signals together and tie them with only one 1K resistor to GND (Check list 1.0).

FOR SG/DIS

MV Modify

SI Del R416, R393, R407, R406, R395, Q31, Q30, Q32

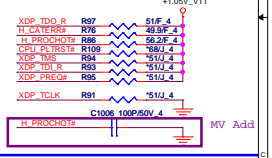

JTAG MAPPING

Scan Chain	STUFF -> Ra, Rc, Re NO STUFF -> Rb, Rd
CPU Only	STUFF -> Ra, Rb NO STUFF -> Rc, Rd, Re
GMCH Only	STUFF -> Rd, Re NO STUFF -> Ra, Rb, Rc

PROJECT : LX6 LX7
Quanta Computer Inc.

Sta	Document Number	Rev
Custom	PROCESSOR 1M(HOST&PEX)	A
Date: Tuesday, February 02, 2010	Sheet 3 of 44	

- +3V 2,7,8,9,10,11,12,13,21,22,23,24,25,26,27,28,29,30,31,32,33,34,37,40,41
- +1.05V_VTT 5,10,11,32,37,38,43
- +1.5VSUS_L 5,41
- +3VS5 8,9,10,11,41

AUBURNDALE/CLARKSFIELD PROCESSOR (DDR3)

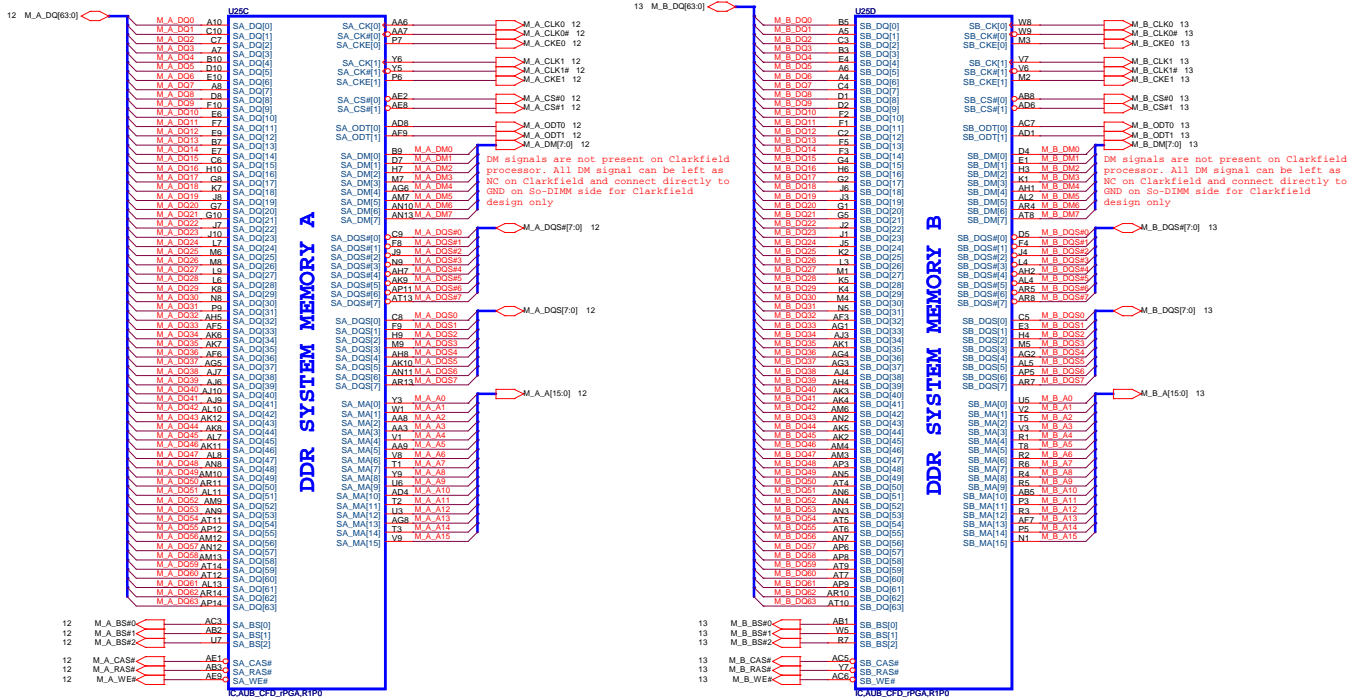

	PROJECT : LX6_LX7		Rev 1A
	Quanta Computer Inc.		
	Size: Custom Document Number: PROCESSOR 24(DDR)	Date: Tuesday, February 02, 2010 Sheet: 4 of 44	

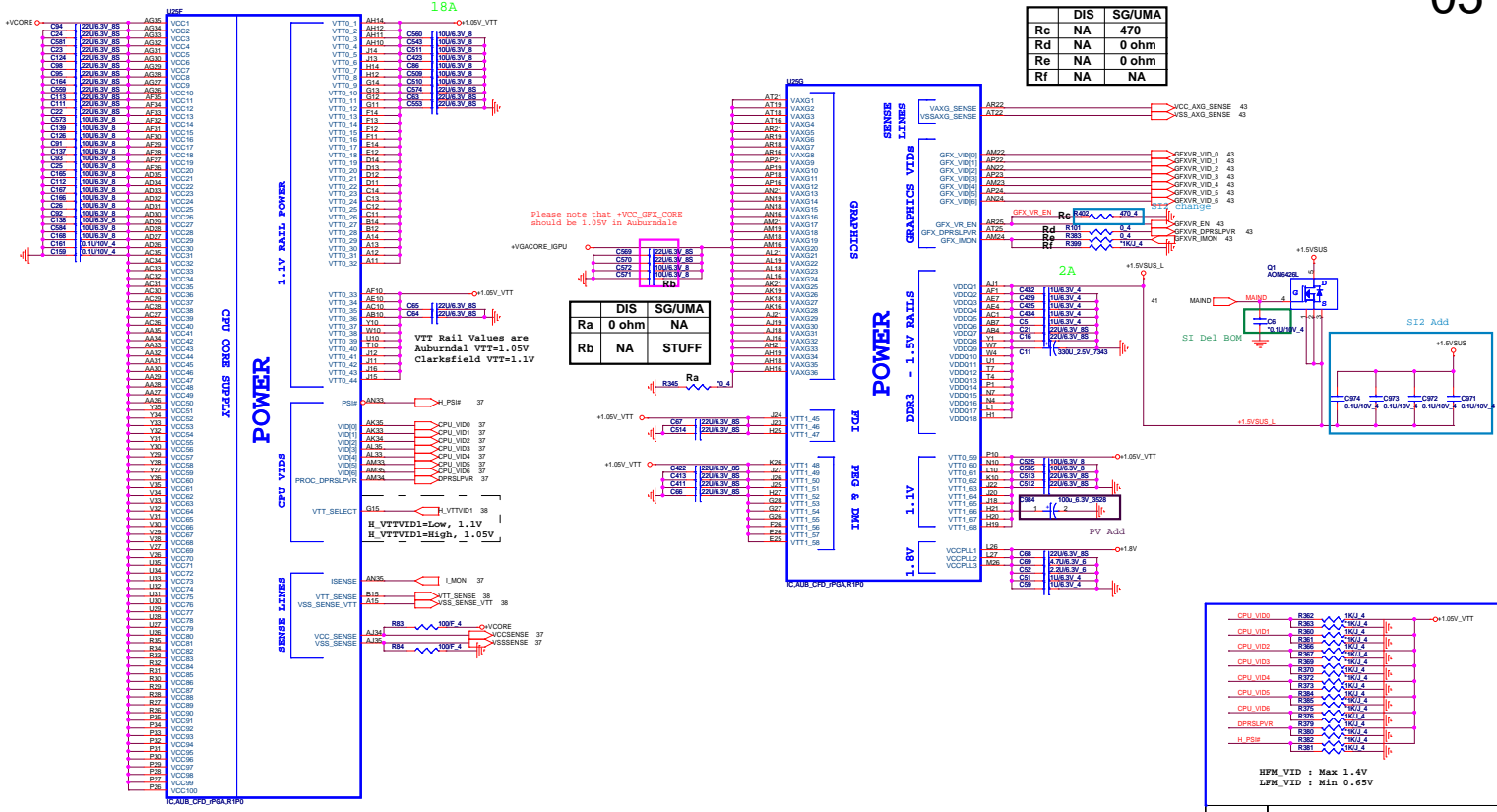

DIS	SG/UMA
Rc	NA
Rd	NA
Re	NA
Rf	NA

Please note that +VCC_GFX_CORE should be 1.05V in Auburndale

Ra	DIS	SG/UMA
Rb	NA	STUFF

Ra	DIS	SG/UMA
Rb	NA	STUFF

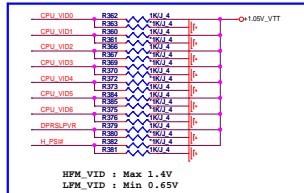

HFM_VID : Max 1.4V
LPM_VID : Min 0.65V

PROJECT : LX6_LX7
Quanta Computer Inc.

Size Custom Document Number **PROCESSOR 3M(POWER)** Rev 1A
Date: Tuesday, February 02, 2010 10:29:41 AM Page 5 of 41

3.41 +1.5V/SUS_L 37
3.10,11,32,37,38,43 +1.05V_VTT 12,13,38,45,41
10,11,21,36,41 +1.0V_VTT

AUBURNDALE/CLARKSFIELD PROCESSOR (GND)

AUBURNDALE/CLARKSFIELD PROCESSOR (RESERVED, CFG)

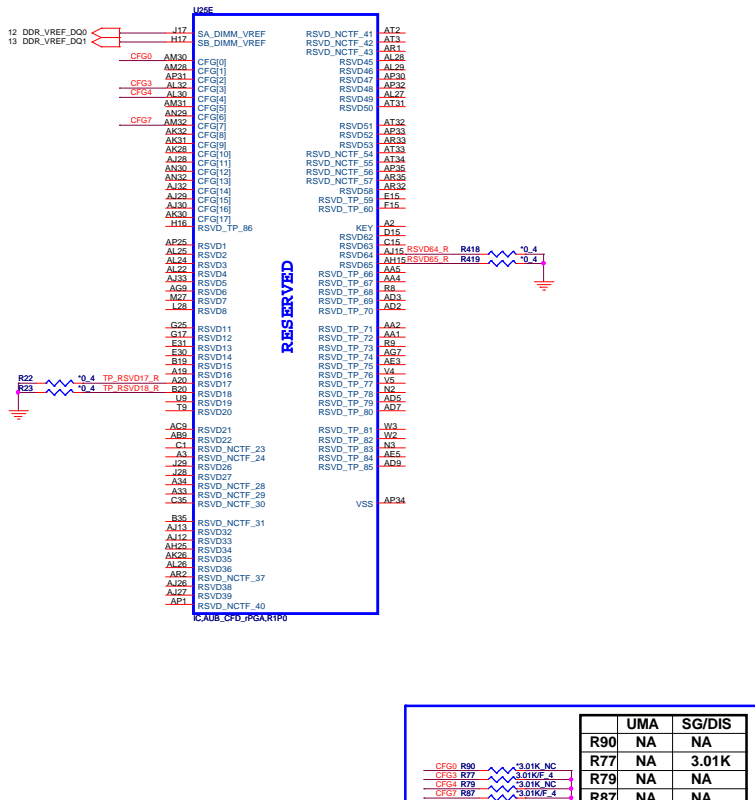
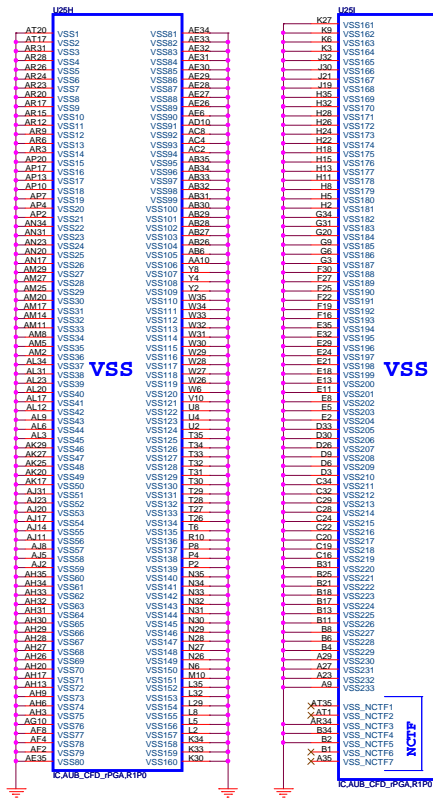

The Clarkfield processor's PCI Express interface may not meet PCI Express 2.0 jitter specifications. Intel recommends placing a 3.01K +/- 5% pull down resistor to VSS on CFG[7] pin for both vPGA and BGA components. This pull down resistor should be removed when this issue is fixed.

	1	0
CFG4 (Display Port Presence)	Disabled; No Physical Display Port attached to Embedded Display Port	Enabled; An external Display port device is connected to the Embedded Display port
CFG0 (PCI-Epress Configuration Select)	Single PEG	Bifurcation enabled
CFG3 (PCI-Epress Static Lane Reversal)	Normal Operation	Lane Numbers Reversed 15 -> 0, 14 -> 1

	UMA	SG/DIS
R90	NA	NA
R77	NA	3.01K
R79	NA	NA
R87	NA	NA

CFG[1:0] - PCI_Epress Configuration Select
 * 11 = 1 x 16 PEG
 * 10 = 2 x 8 PEG

PROJECT : LX6 LX7
Quanta Computer Inc.

NB5
 Size Custom Document Number **PROCESSOR 4/4 (GND)** Rev 1A
 Date: Tuesday, February 02, 2010 Sheet 6 of 44

INTRVMMEN - Integrated SUS 1.1V VSM Enable
High - Enable Internal VRs

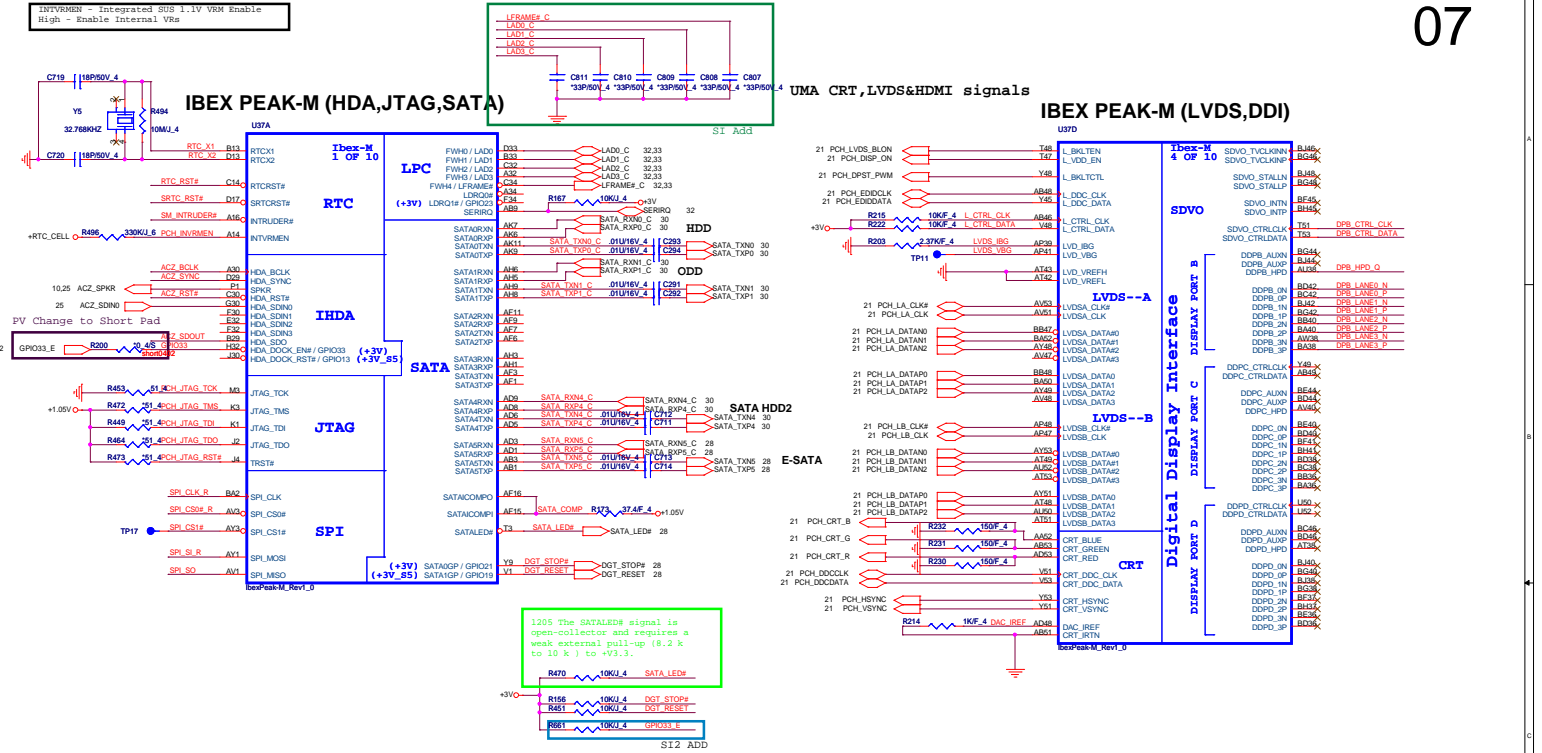

1.205 V_{DD} SATALED# signal is open-collector and requires a weak external pull-up (8.2 k to 10 k) to +V3.3.

R470 100K 4 SATA_LED#

R156 100K 4 DGT_STOP#

R461 100K 4 DGT_RESET

R461 100K 4 GPO33_E

ST2 ADD

PROJECT : LX6_LX7
Quanta Computer Inc.

Rev	Document Number	Rev
Custom	PCH 1/5 (SATA,HDA,LPC)	1A
Date	Yusuf, February 02, 2010	Sheet
		7 of 44

AV1	VSS159	VSS259	H49
B11	VSS160	VSS260	H5
B19	VSS161	VSS261	K44
B19	VSS162	VSS262	K11
B23	VSS163	VSS263	K43
B31	VSS164	VSS264	K7
B36	VSS165	VSS265	K17
B41	VSS166	VSS266	L14
B47	VSS168	VSS268	L2
B7	VSS169	VSS269	L12
BG12	VSS170	VSS270	L32
BG12	VSS171	VSS271	L38
BB16	VSS172	VSS272	L40
BB24	VSS173	VSS273	M12
BB24	VSS174	VSS274	M16
BB30	VSS175	VSS275	M16
BB34	VSS176	VSS276	M20
BB36	VSS177	VSS277	N38
BB38	VSS178	VSS278	M38
BB5	VSS179	VSS279	M42
BC10	VSS180	VSS280	M46
BC14	VSS182	VSS282	M49
BC5	VSS183	VSS283	M8
BC2	VSS184	VSS284	M8
BC2	VSS185	VSS285	P11
BC30	VSS186	VSS286	A015
BC40	VSS187	VSS287	P22
BC1	VSS188	VSS288	N24
BC44	VSS189	VSS289	P26
BC50	VSS189	VSS289	P26
BH8	VSS191	VSS291	P34
BD39	VSS192	VSS292	P45
BE12	VSS194	VSS294	P2
BE12	VSS195	VSS295	P2
BE16	VSS196	VSS296	RS2
BE24	VSS197	VSS297	T41
BE31	VSS198	VSS298	T46
BE34	VSS199	VSS299	T48
BE34	VSS200	VSS300	L5
BE42	VSS201	VSS301	L5
BE46	VSS203	VSS303	L30
BE50	VSS205	VSS305	L32
BE50	VSS205	VSS305	L32
BE8	VSS206	VSS306	P38
BF3	VSS208	VSS308	T11
BF40	VSS209	VSS309	P16
BF51	VSS210	VSS310	V19
BG14	VSS211	VSS311	V20
BG14	VSS212	VSS312	V22
BG50	VSS213	VSS313	V31
BH11	VSS215	VSS315	V32
BH11	VSS216	VSS316	V34
BH19	VSS217	VSS317	V35
BH19	VSS218	VSS318	V38
BH31	VSS219	VSS319	V45
BH39	VSS220	VSS320	V46
BF43	VSS221	VSS321	V47
BF43	VSS222	VSS322	V48
BH7	VSS224	VSS324	V5
CG1	VSS225	VSS325	V8
E12	VSS226	VSS326	M52
E16	VSS228	VSS328	V11
E20	VSS229	VSS329	V12
E24	VSS231	VSS331	V15
E30	VSS232	VSS332	V28
E34	VSS233	VSS333	V29
E42	VSS234	VSS334	V30
E46	VSS235	VSS335	V32
E48	VSS237	VSS337	V32
E6	VSS238	VSS338	V38
F8	VSS239	VSS339	V43
F49	VSS240	VSS340	V46
G10	VSS241	VSS341	V49
G14	VSS242	VSS342	V49
G14	VSS243	VSS343	V6
G18	VSS244	VSS344	V6
G2	VSS245	VSS345	P24
G2	VSS246	VSS346	T43
G32	VSS247	VSS347	A07
G40	VSS248	VSS348	A07
G40	VSS249	VSS349	A07
G44	VSS250	VSS350	V47
G52	VSS251	VSS351	AM6
H16	VSS252	VSS352	AT13
H20	VSS253	VSS353	AM5
H40	VSS255	VSS355	AK45
H51	VSS256	VSS356	AK39
H58	VSS257	VSS357	V14
H58	VSS258	VSS358	V14

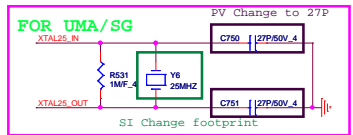
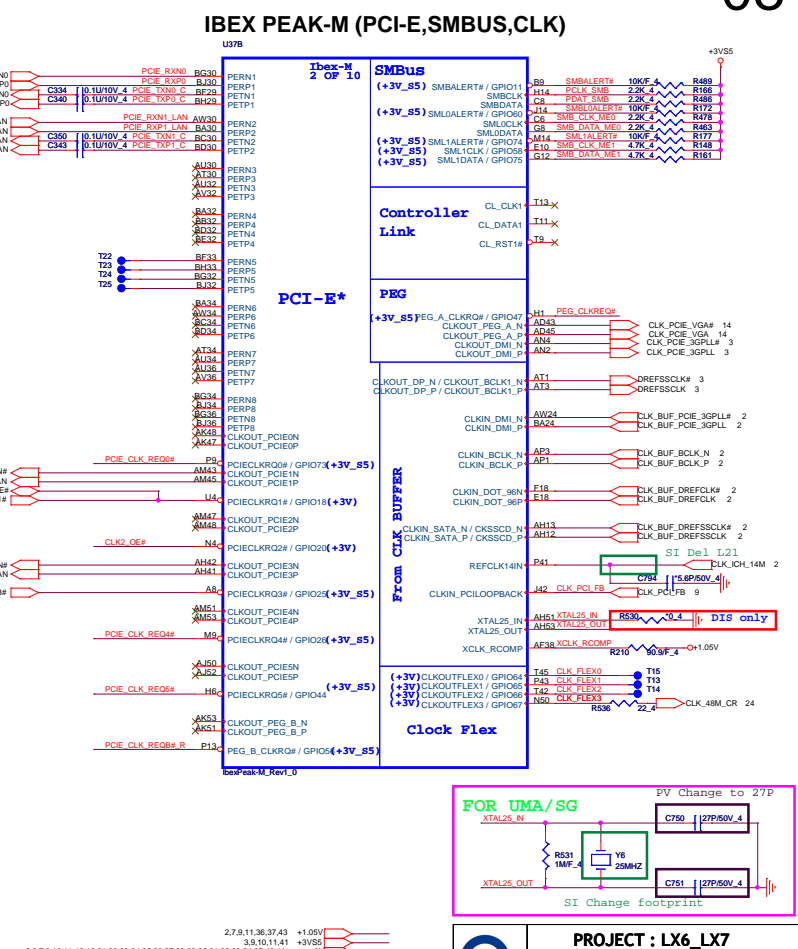
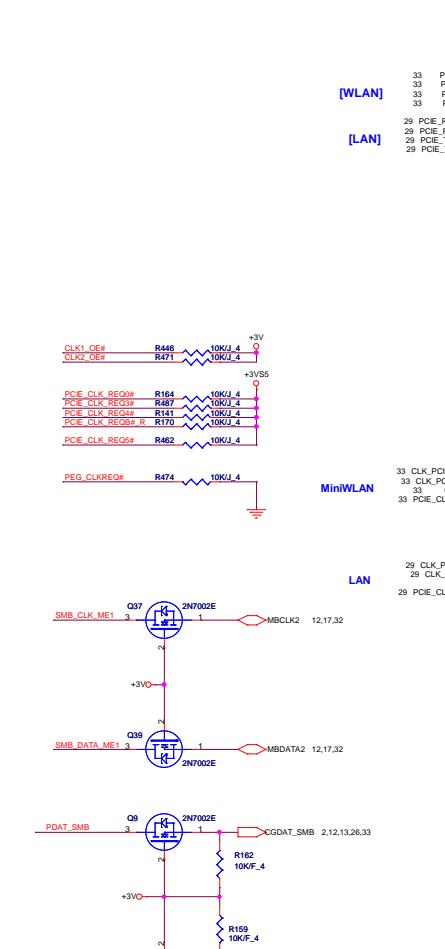

PROJECT : LX6 LX7
Quanta Computer Inc.

Site Custom	Document Number: PCH 0/5 (PCIE, SMBUS, CK)	Rev. 1A
Date: Tuesday, February 02, 2010	Sheet: 8 of 44	

IBEX PEAK-M (PCI,USB,NVRAM)

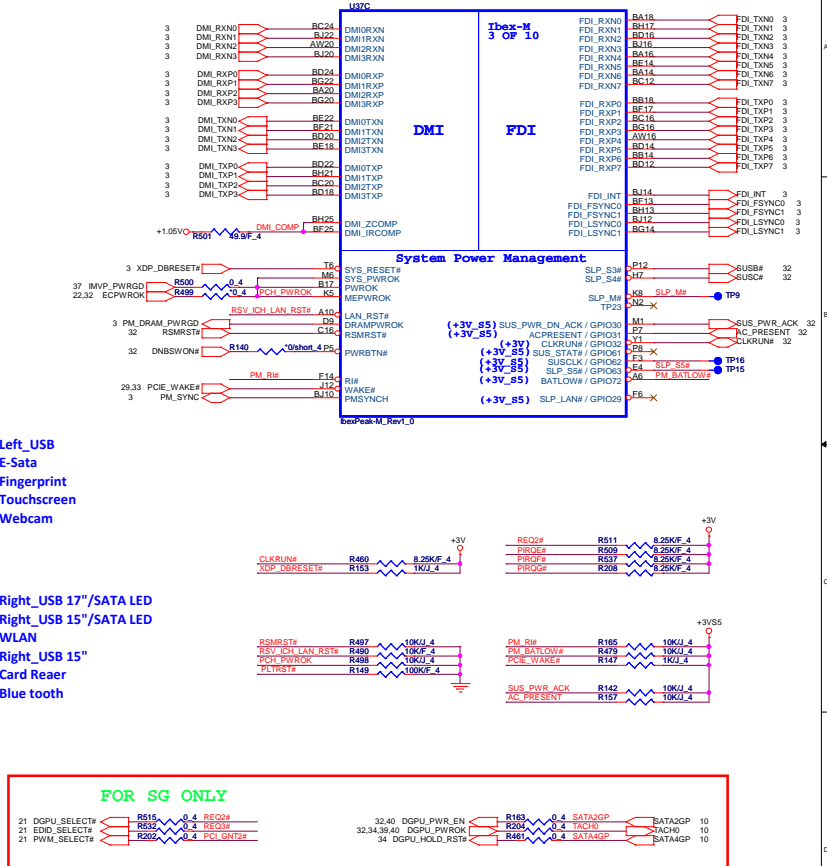
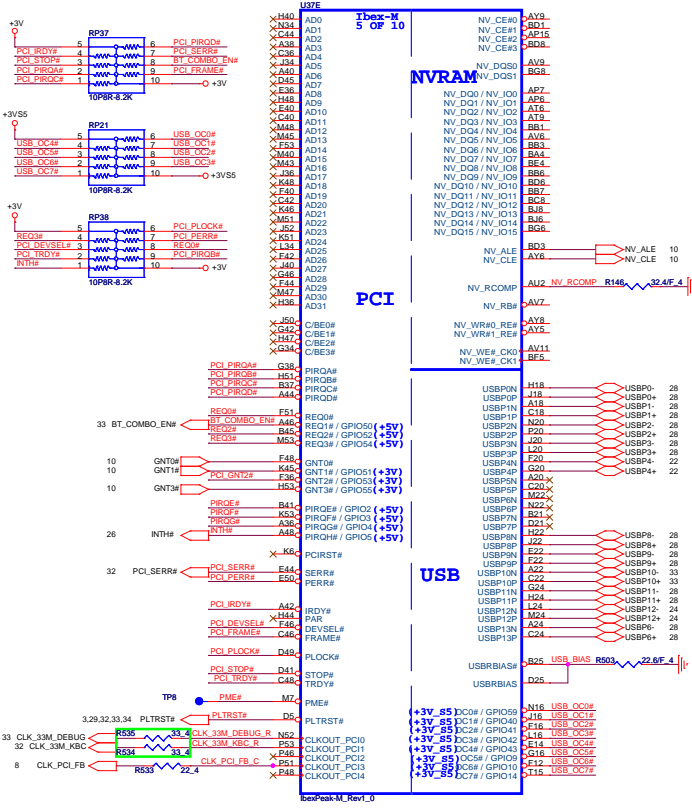

Quanta Computer Inc.

PROJECT : LX6_LX7

Size: Custom Document Number: **PCH 3/5 (PCI,ONFI,USB,DMI)** Rev: 1A

Date: Tuesday, February 02, 2010 Sheet: 9 of 44

2.7,8,10,11,12,13,21,22,23,24,25,26,27,28,29,30,31,32,33,34,37,40,41
3.8,10,11,41 +3V
+1.05V

IBEX PEAK-M (GPIO,VSS_NCTF,RSVD)

IBEX PEAK-M (GND)

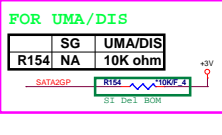
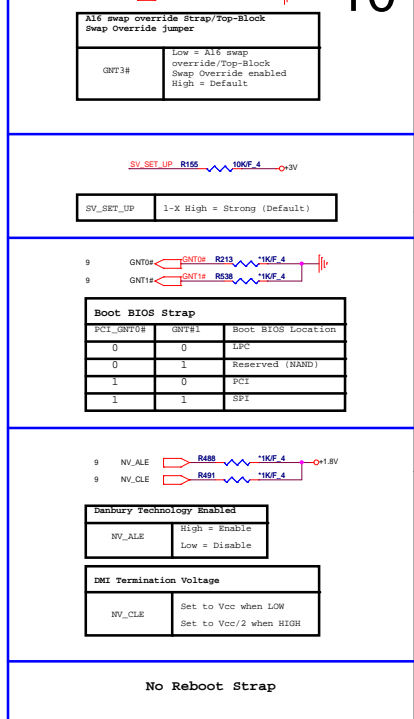
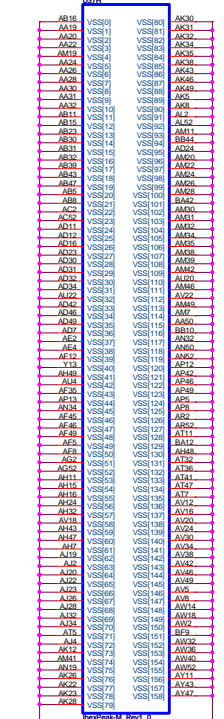
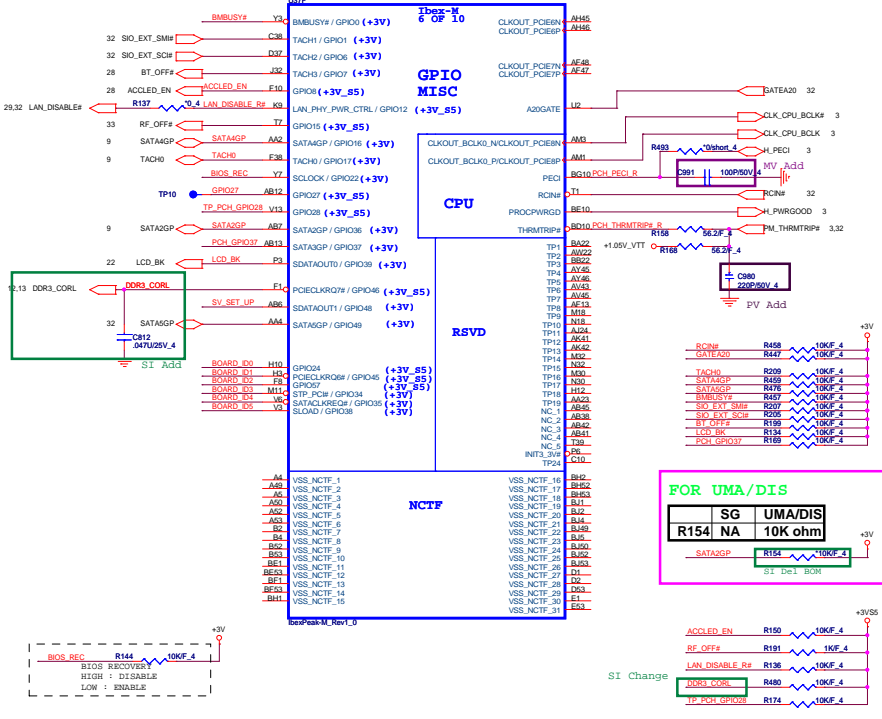

BOARD ID SETTING

Board ID	IDS	ID4	ID3	ID2	ID1	ID0
TBD	RD5 (0)	RD4 (0)	RD3 (0)	RD2 (0)	RD1 (0)	RU0 (1)
TBD	RD5 (0)	RD4 (0)	RD3 (0)	RD2 (0)	RU1 (1)	RD0 (0)
TBD	RD5 (0)	RD4 (0)	RD3 (0)	RU2 (1)	RD1 (0)	RD0 (0)
TBD	RD5 (0)	RD4 (0)	RD3 (0)	RU2 (1)	RU1 (1)	RD0 (0)
TBD	RD5 (0)	RD4 (0)	RD3 (0)	RU2 (1)	RU1 (1)	RU0 (1)
TBD	RD5 (0)	RD4 (0)	RD3 (0)	RU2 (1)	RU1 (1)	RU0 (1)
TBD	RD5 (0)	RD4 (0)	RD3 (0)	RU2 (1)	RU1 (1)	RU0 (1)
TBD	RD5 (0)	RD4 (0)	RD3 (0)	RU2 (1)	RU1 (1)	RU0 (1)
LX7_No Subwoofer	1	1				

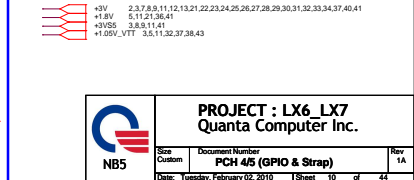
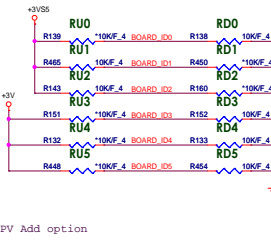
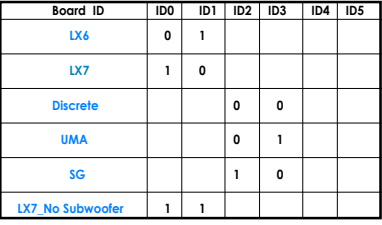

PROJECT : LX6_LX7
Quanta Computer Inc.

See	Document Number	Rev
Order	PCN 445 (GPIO & Strap)	1A
Date	Monday, February 13, 2010	1 of 44

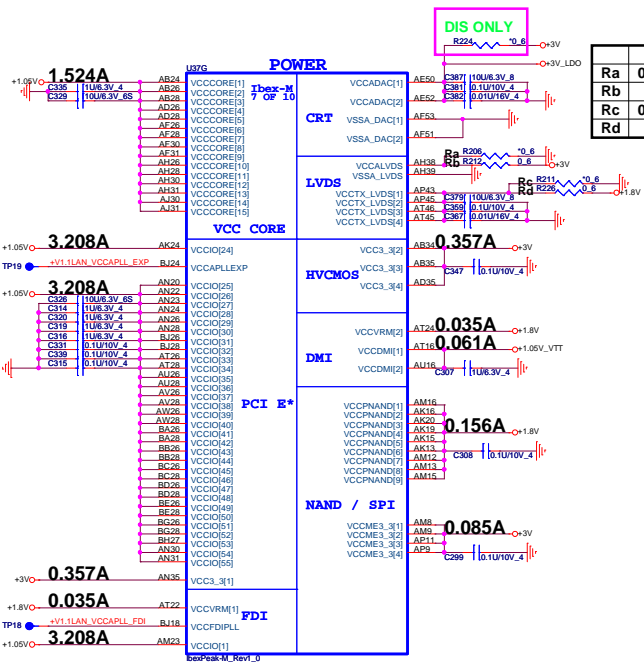

	DIS	SG/UMA
Ra	0 ohm	NA
Rb	NA	0 ohm
Rc	0 ohm	NA
Rd	0 ohm	0 ohm

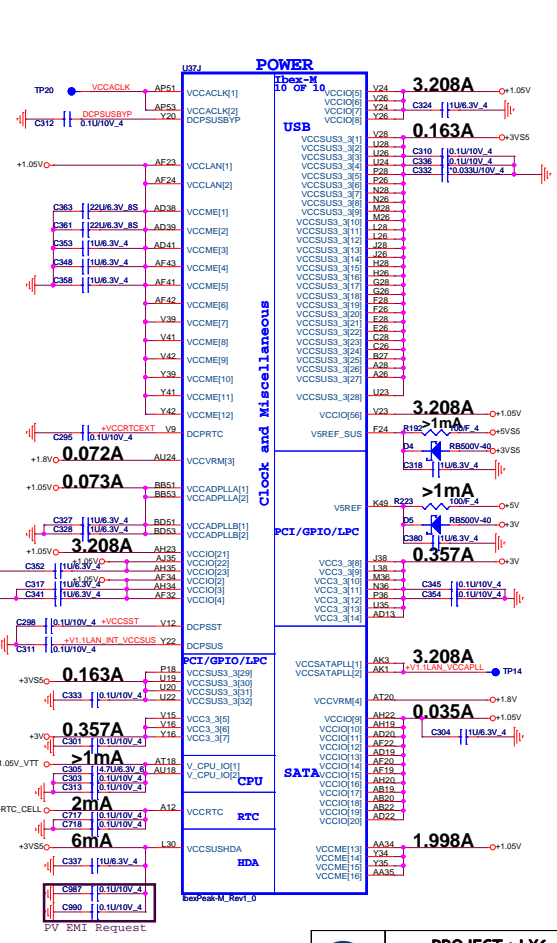
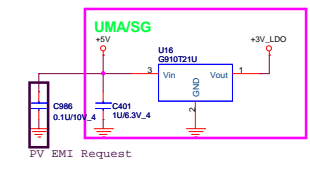

2,7,8,9,36,37,43	+1.05V
3,5,10,32,37,38,43	+1.05V_VTT
5,10,21,36,41	+1.8V
2,3,7,8,9,10,12,13,21,22,23,24,25,26,27,28,29,30,31,32,33,34,37,40,41	+3V
41	+3.0V_10.41
21,22,23,25,26,28,30,31,33,34,41	+5V
41	+5V
7	+RTC_CELL

PROJECT : LX6_LX7
Quanta Computer Inc.

Size: Custom Document Number: **PCH S/S (POWER)** Rev: 1A

Date: Tuesday, February 02, 2010 | Sheet 11 of 44

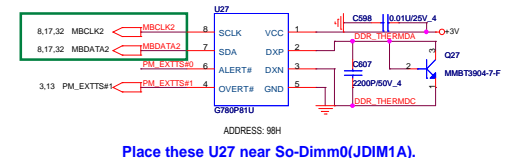
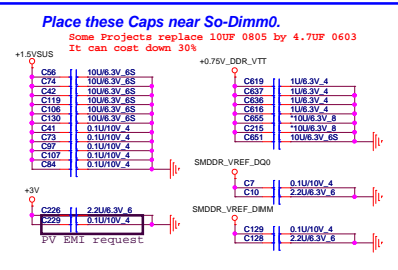
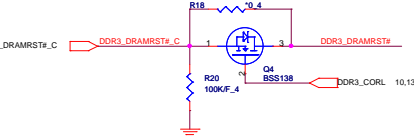
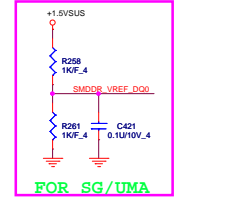
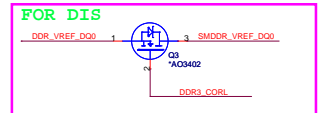
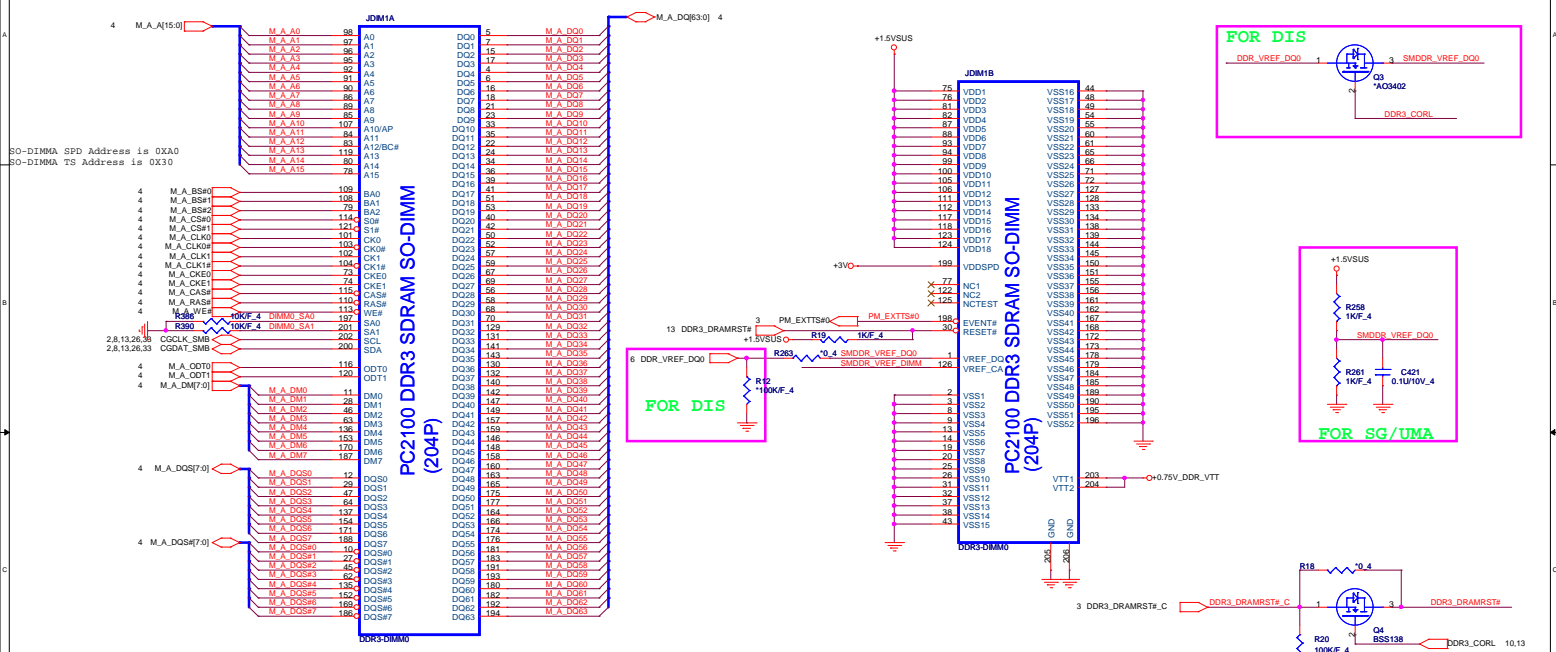

Place these U27 near So-Dimm0(JDM1A).

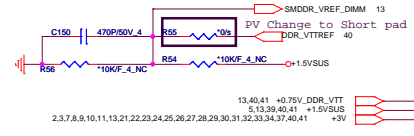

PROJECT : LX6_LX7
Quanta Computer Inc.

Size: Custom | Document Number: **DDR3_DIMM-0** | Rev: 1A

Date: Tuesday, February 02, 2010 | Sheet: 12 of 44

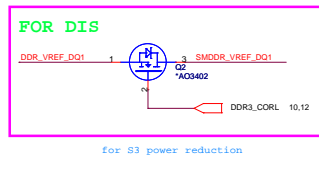
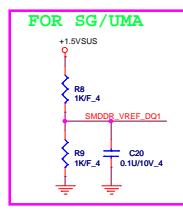
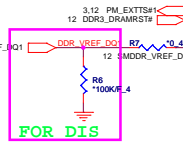
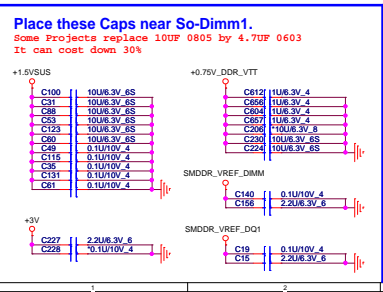
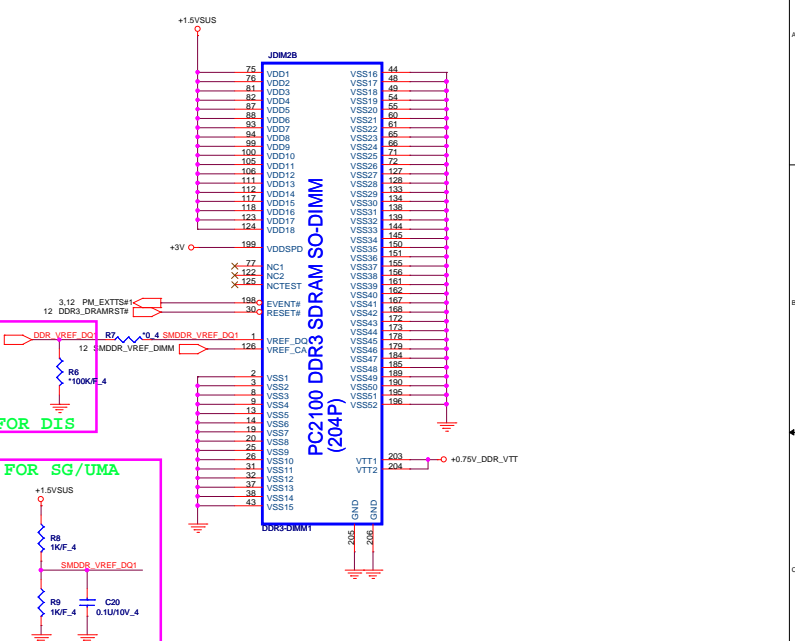
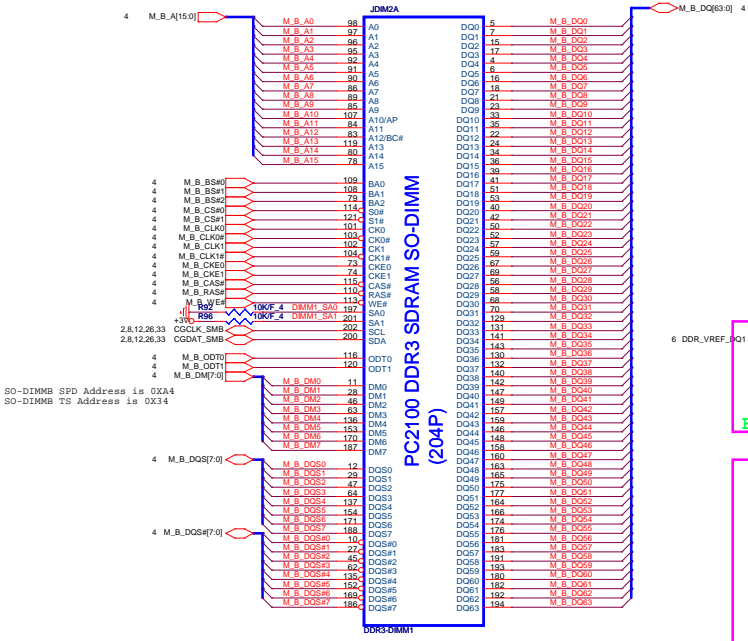

12.40.41 +0.75V_DDR_VTT
5.12.39-40.41 +1.5VSUS
2.3.7.8.9.10.11.12.21.22.23.24.25.26.27.28.29.30.31.32.33.34.37.40.41 +3V

PROJECT : LX6_LX7
Quanta Computer Inc.

Size (Custom)	Document Number: DDR3 DIMM-1	Rev: 1A
Date: Tuesday, February 02, 2010		Sheet: 13 of 44

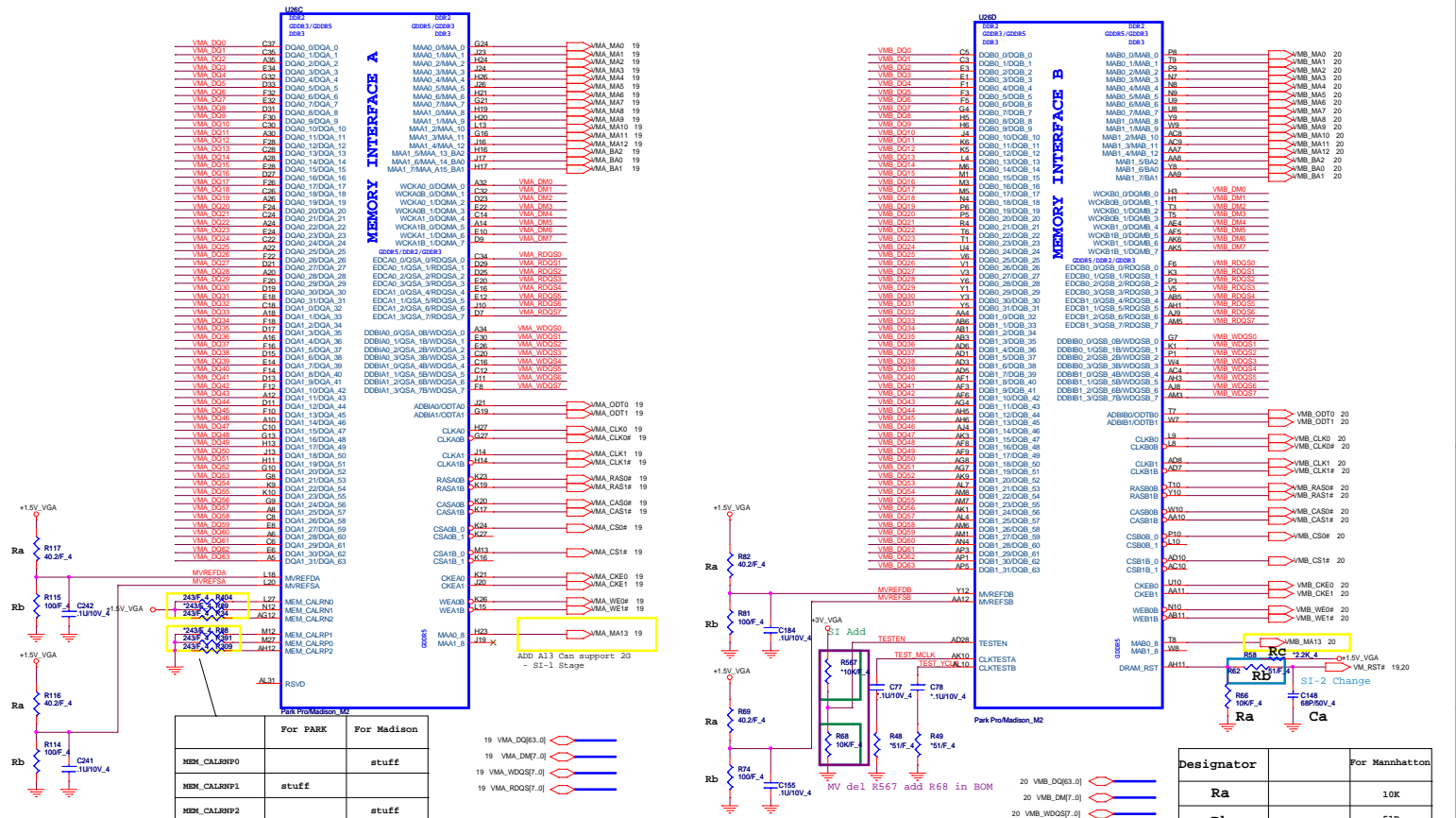

	For PARK	For Madison
MEM_CALRN0		stuff
MEM_CALRN1		stuff
MEM_CALRN2		stuff

DDR3/GDDR3 Memory Stuff Option

	GDDR5	GDDR3	DDR3
+1.5V_VGA	1.5V	1.8V/1.5V	1.5V
Ra	40.2R	40.2R	40.2R
Rb	100R	100R	100R

Designator	For Manhattan
Ra	10K
Rb	51R
Rc	DNI
Ca	68pF

PROJECT : LX6_LX7
Quanta Computer Inc.

Rev 1A
Date: Tuesday, February 02, 2010 Sheet 15 of 44

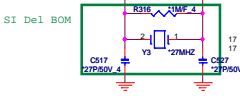
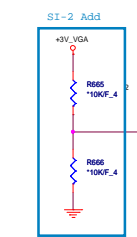
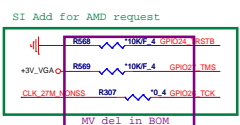
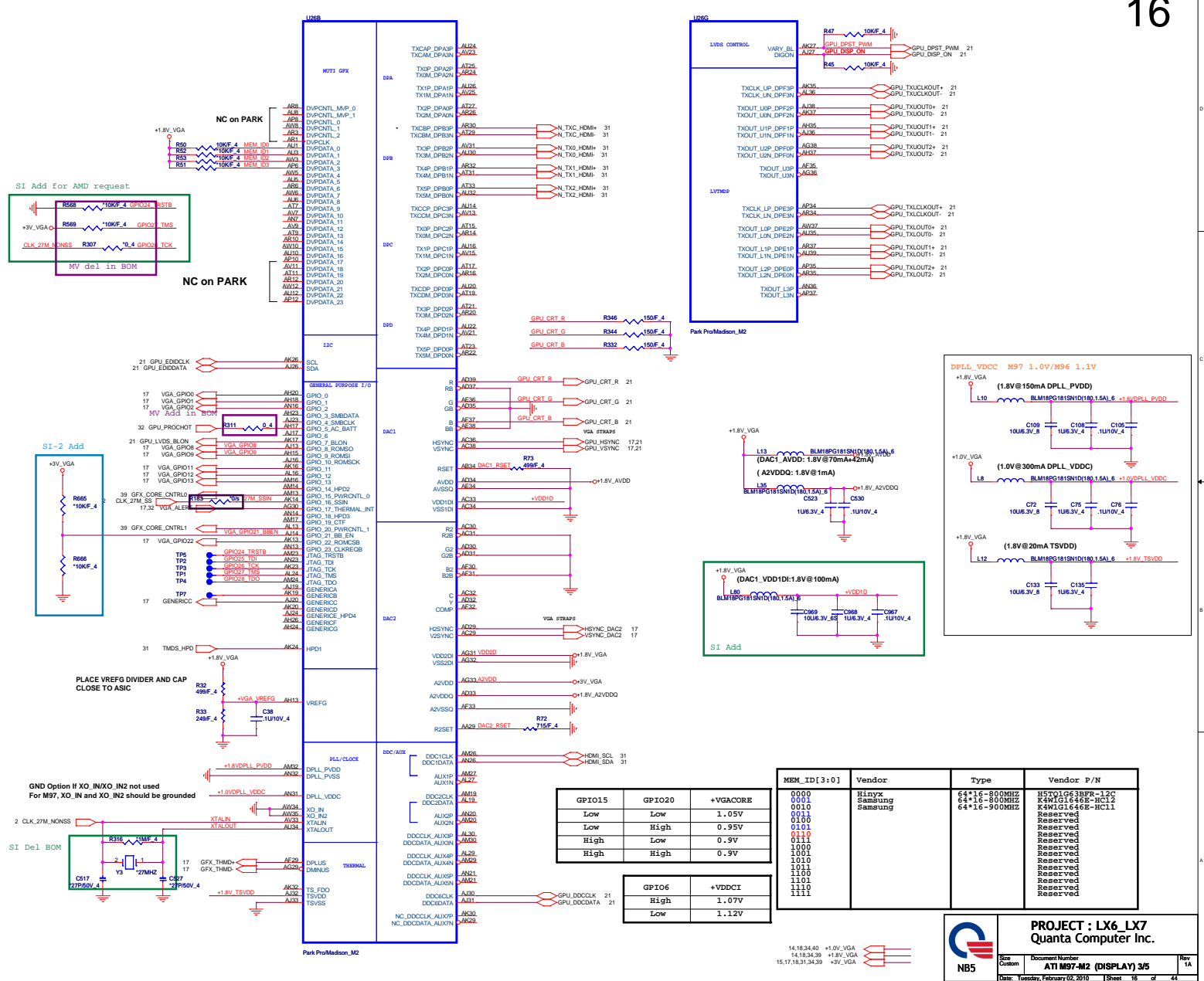

MEM_ID[3+0]	Vendor	Type	Vendor P/N
0000	Elmetec	64*16-80MHz	H57VL063887-12C
0010	Samsung	64*16-80MHz	K4WG1648E-HC12
0100		64*16-80MHz	Reserved
0101		64*16-80MHz	Reserved
0110		64*16-80MHz	Reserved
0111		64*16-80MHz	Reserved
1000		64*16-80MHz	Reserved
1001		64*16-80MHz	Reserved
1010		64*16-80MHz	Reserved
1011		64*16-80MHz	Reserved
1100		64*16-80MHz	Reserved
1101		64*16-80MHz	Reserved
1110		64*16-80MHz	Reserved
1111		64*16-80MHz	Reserved

GPIO	Level	+VGCORE
GPIO15	Low	1.05V
GPIO20	High	0.95V
GPIO6	High	+VDDCI
	High	1.07V
	Low	1.12V

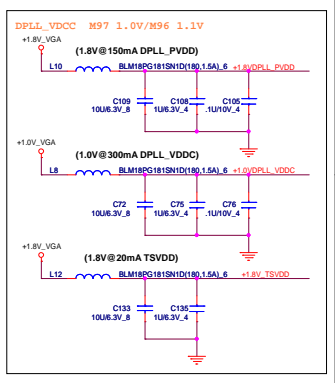

PROJECT : LX6_LX7
Quanta Computer Inc.

14.18.34.40 +1.0V_VGA
 14.18.34.39 +1.8V_VGA
 15.17.18.31.34.39 +3V_VGA

Rev	Document Number	Rev
1	ATI M97-M2 (DISPLAY) 3/5	1A

Date: Tuesday, February 02, 2010 10:01:18 AM of 44

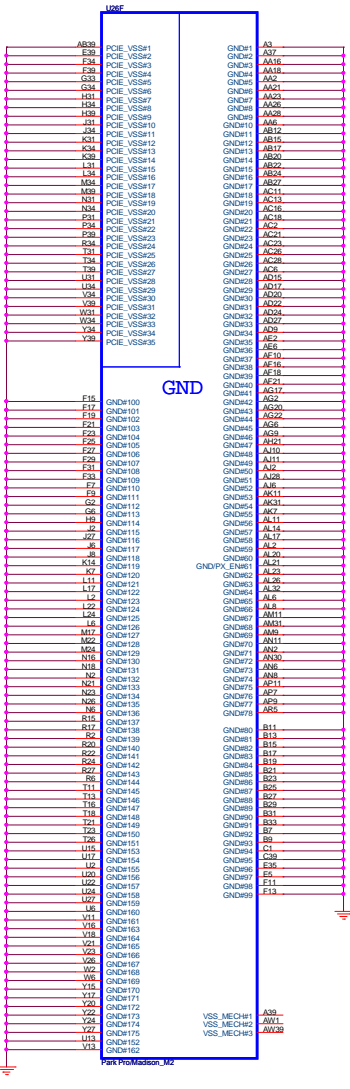

STRAPS

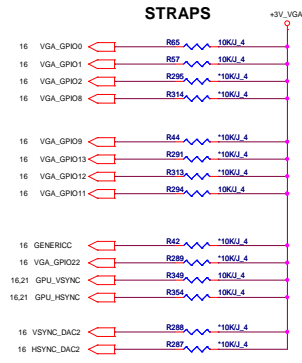

Memory Aperture size fix 256M

GPIO9 BIOSROM	GPIO13 ROMIDCFG2	GPIO12 ROMIDCFG1	GPIO11 ROMIDCFG0
0	128M	0	0
0	256M	0	1
0	64M	0	1
0	32M	0	1
0	512M	1	0
0	1G	1	0
0	2G	1	0
0	4G	1	1

CONFIGURATION STRAPS			RECOMMENDED SETTINGS
ALLOW FOR PULLUP PADS FOR THESE STRAPS AND IF THESE GPIOs ARE USED, THEY MUST NOT CONFLICT DURING RESET			D= DO NOT INSTALL RESISTOR R= INSTALL 10K RESISTOR X= DESIGN DEPENDANT NA= NOT APPLICABLE
STRAPS	PIN	DESCRIPTION OF DEFAULT SETTINGS	
TX_PWRS_ENB	GPIO0	Transmitter Power Savings Enable 0: 50% Tx output swing for mobile mode 1: 50% Tx output swing (Default setting for Desktop)	1
TX_DEEMPH_EN	GPIO1	PCI Express Transmitter De-emphasis Enable 0: Tx de-emphasis disabled for mobile mode 1: Tx de-emphasis enabled (Default setting for Desktop)	1
BIF_GEN2_EN_A	GPIO2	0 = Advertises the PCI-E device as 2.5 GT/s capable at power-on. 1 = Advertises the PCI-E device as 3.0 GT/s capable at power-on. E-GT/s capability will be controlled by software.	0
RSVD BIF_VGA_DIS RSVD	GPIO8 GPIO9 GPIO21	VGA ENABLED	0 0 0
BIOS_ROM_EN	GPIO 22_ROMCSB	ENABLE EXTERNAL BIOS ROM	0
ROMIDCFG2(S)	GPIO13-11	SERIAL ROM TYPE OR MEMORY APERTURE SIZE SELECT	0 0 1
VIP_DEVICE_STRAP_ENA	V2SYNC	IGNORE VIP DEVICE STRAPS	0
RSVD AUD1[0] AUD[0]	GENERIC HSYNC VSYNC	AUD1[0] AUD[0] 0: No audio function 1: 0 Audio for DisplayPort and HDMI if dongle is detected 1: 0 Audio for DisplayPort only 1: 1 Audio for both DisplayPort and HDMI	0 0 11

AMD RESERVED CONFIGURATION STRAPS

AMD RESERVED CONFIGURATION STRAPS		
ALLOW FOR PULLUP PADS FOR THESE STRAPS AND IF THESE GPIOs ARE USED, THEY MUST NOT CONFLICT DURING RESET		
HSYNC	GENERIC	
PULLUP PADS ARE NOT REQUIRED FOR THESE STRAPS BUT IF THESE GPIOs ARE USED, THEY MUST NOT CONFLICT DURING RESET		
GPIO21_BB_EN		

It is a shared pin strap with CONF1G[2:0] if BIOS_ROM_EN is set to 0.

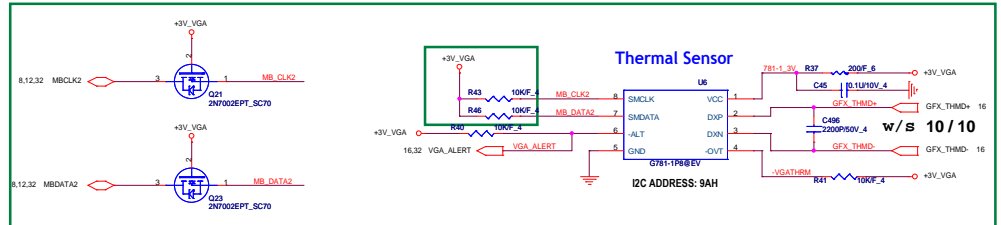

PROJECT : LX6_LX7
Quanta Computer Inc.

Doc: **ATI M97(GND&Str&Ther)4/5**

Doc Number: **ATI M97(GND&Str&Ther)4/5**

Date: **Tuesday, February 02, 2010** Sheet **17** of **44**

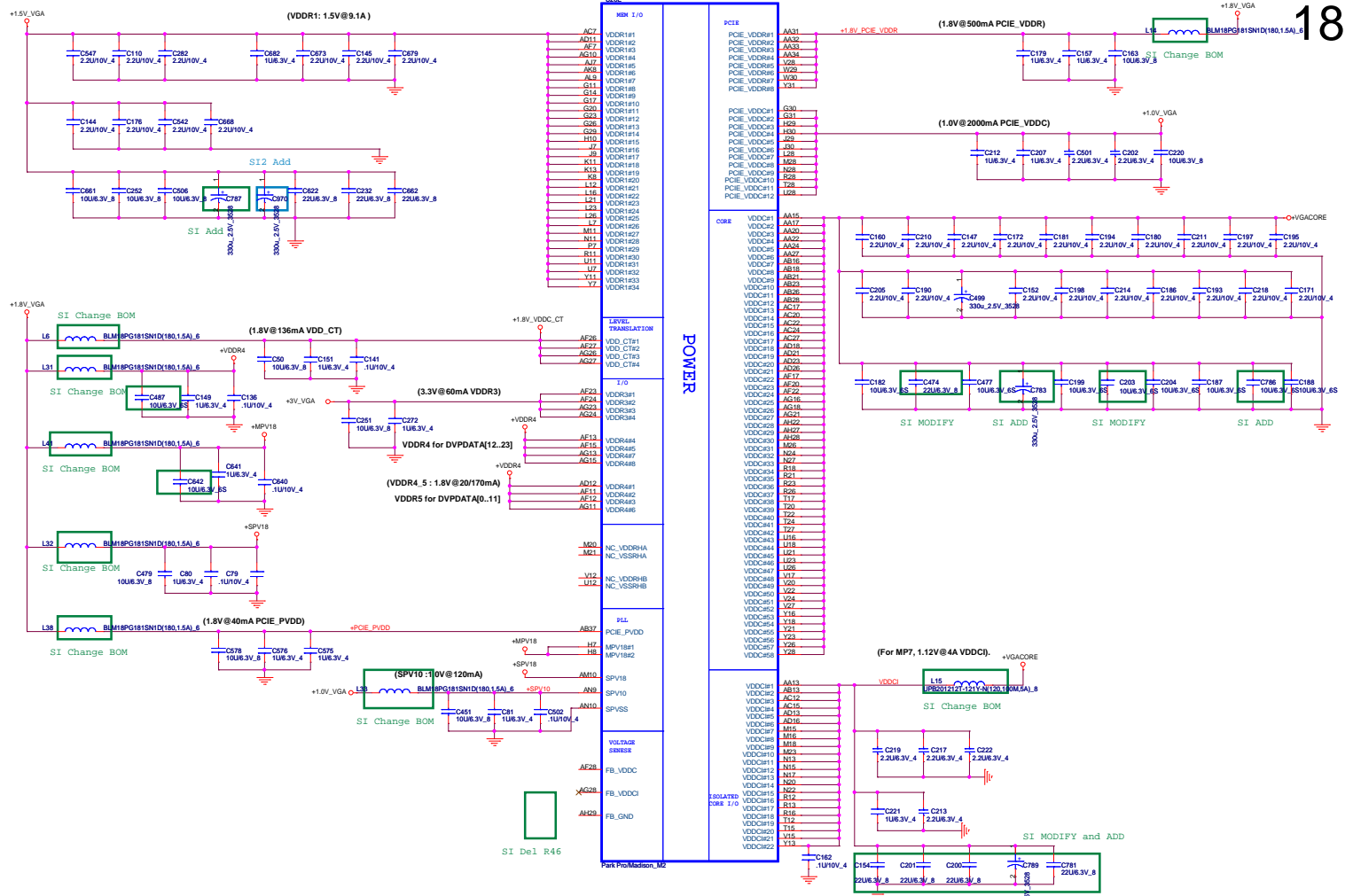

PROJECT : LX6_LX7
Quanta Computer Inc.

NB5

Doc Number: **ATI M97-M2 (POWER) 5/5**

Date: **Tuesday, February 02, 2010** | Sheet **18** of **44**

CHANNEL B: 256MB/512MB DDR3

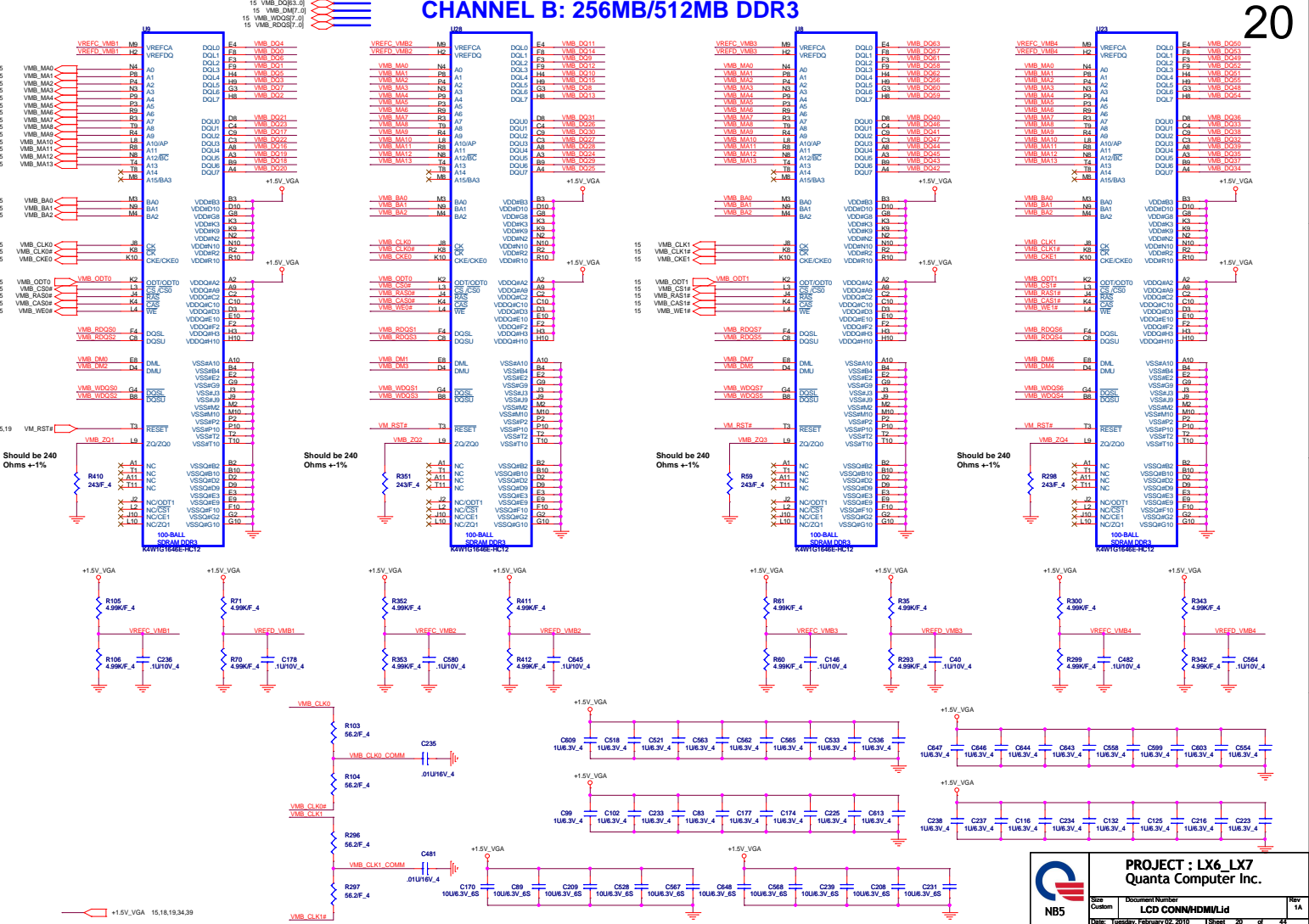

PROJECT : LX6_LX7
Quanta Computer Inc.

Rev: 01	Document Number: LCD_CONN/HW/Ltd	Rev: 1A
Date: Tuesday, February 02, 2010	Title: Sheet 20 of 44	

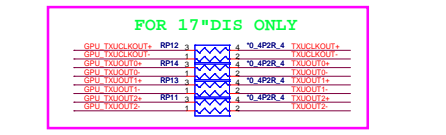
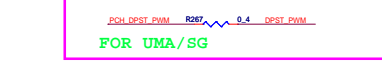
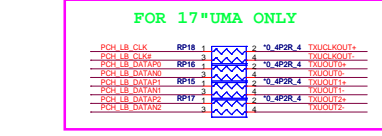
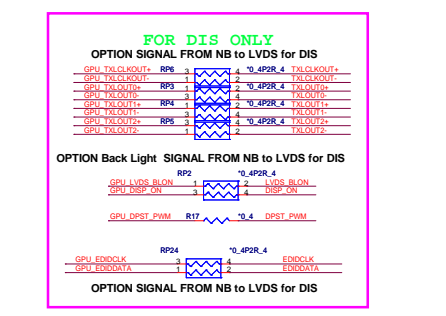
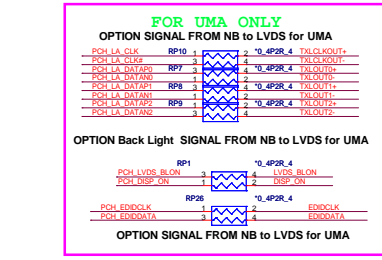
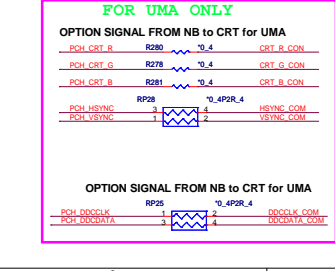
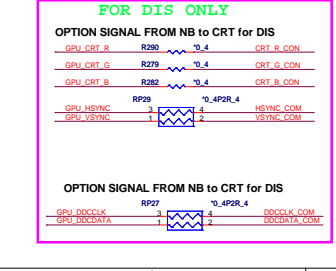
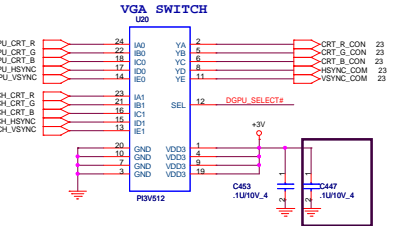
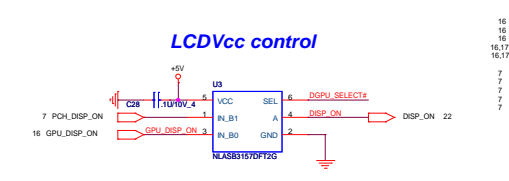
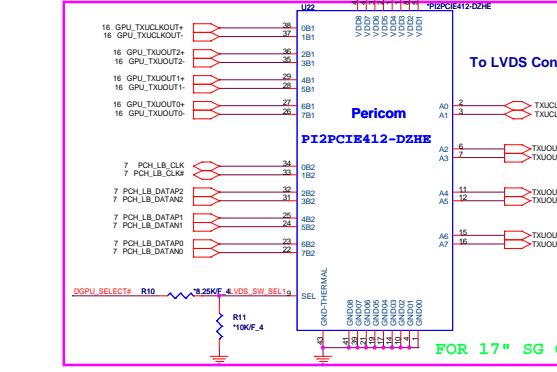
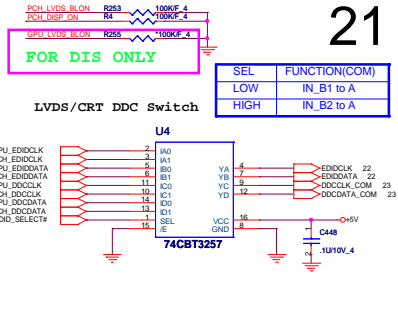
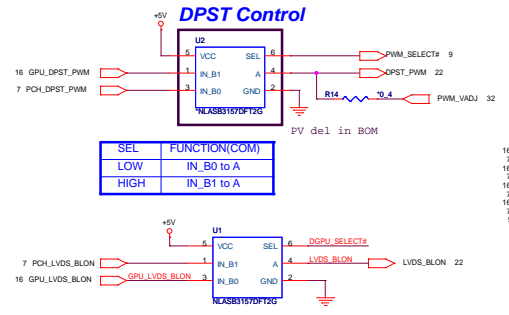
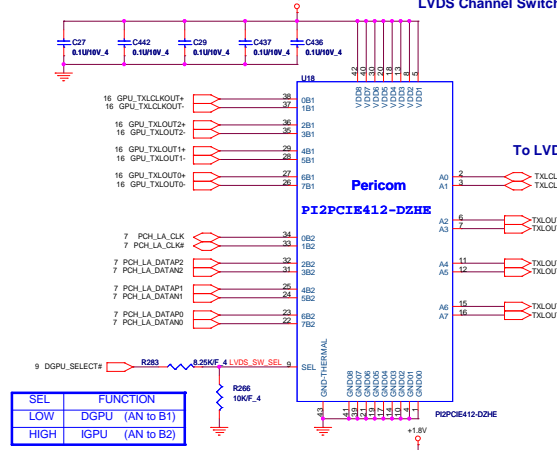

+3V
 +5V
 +1.8V

2,3,7,8,9,10,11,12,13,22,23,24,25,26,27,28,29,30,31,32,33,34,37,40,41
 5,10,11,35,41

PROJECT : LX6_LX7
Quanta Computer Inc.

NB5
 Switchable
 Rev 1A

Date: Tuesday, February 02, 2010 Sheet 21 of 44

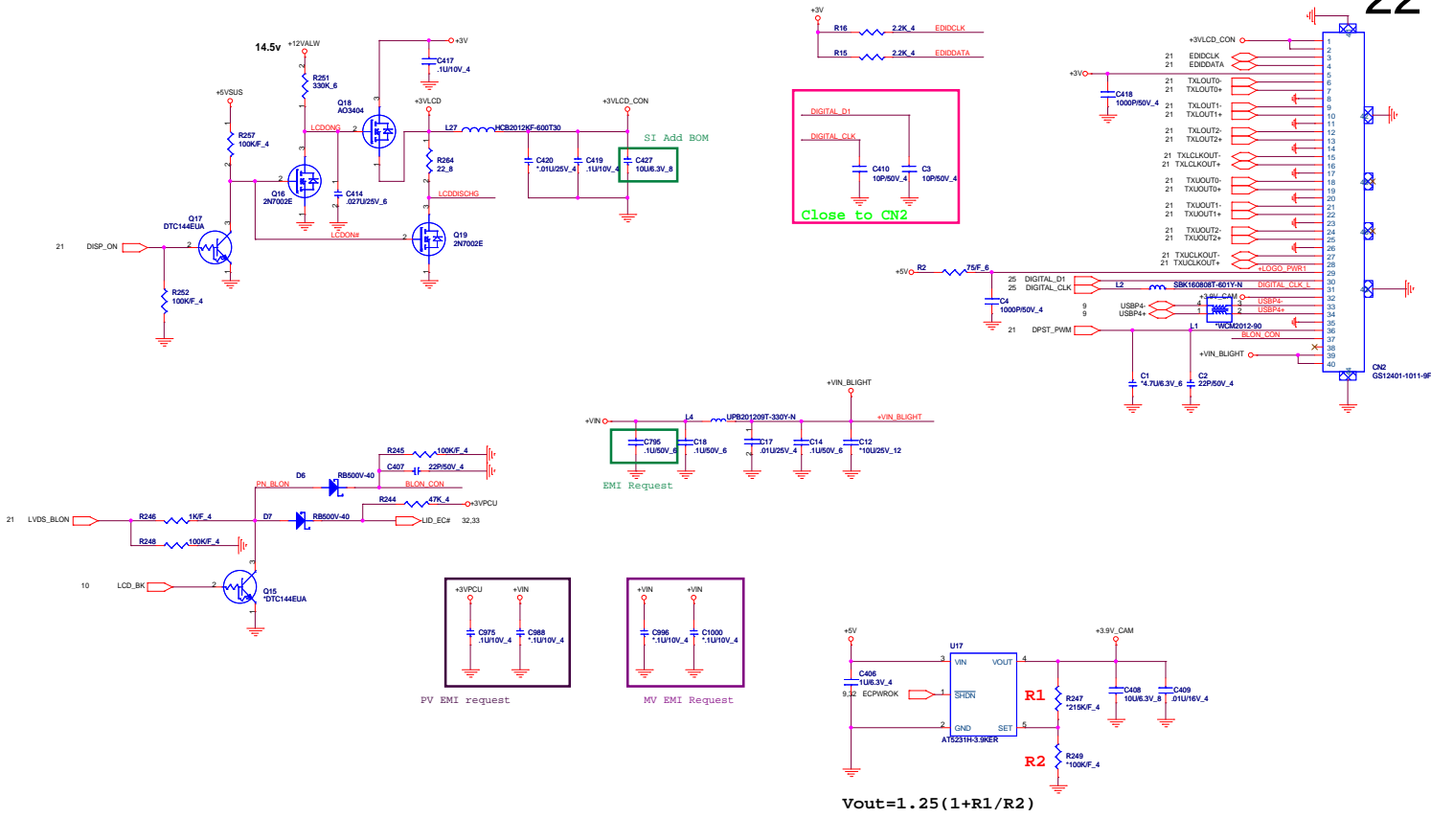

- 2,3,7,8,9,10,11,12,13,21,23,24,25,26,27,28,29,30,31,32,33,34,37,40,41 +3V
- 11,21,23,25,26,28,30,31,33,34,41 +5V
- 27,35,36,37,39,40,41,42,43 +VIN
- 7,28,32,33,34,35,36,39,41,42,43 +3VPCU
- 30,34,39,41 +12VALW

$V_{out} = 1.25 (1 + R1/R2)$

	PROJECT : LX6_LX7 Quanta Computer Inc.		Rev 1A
	Doc LCD_CONN/LID function	Date Tuesday, February 03, 2010	

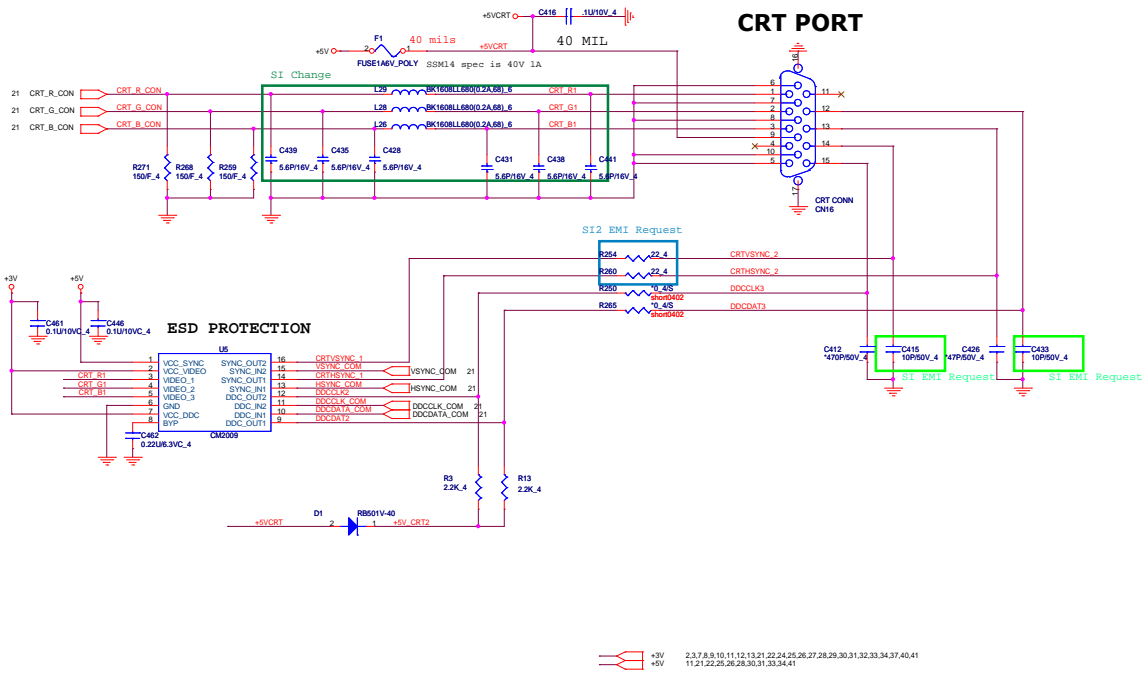

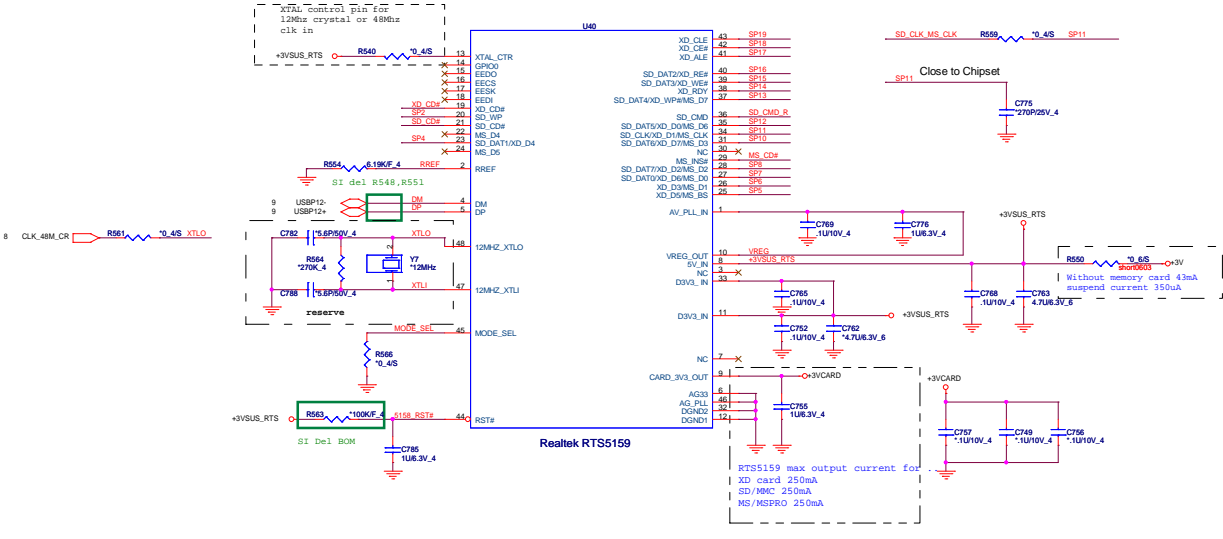

Note:

SP0	SD/MMC	MS	XD
SP1	SD_WP		XD_CLE
SP2	SD_CBE		
SP3	SD_DATA1		XD_D4
SP4	SD_DATA2		XD_D5
SP5	US_B1	MS_B1	XD_D6
SP6	US_B2	MS_B2	XD_D7
SP7	SD_DATA0	MS_D0	XD_D8
SP8	SD_DATA7	MS_D7	XD_D9
SP9	SD_DATA6	MS_D6	XD_D10
SP10	SD_CLK	US_SCLK	XD_D11
SP11	SD_DATA5		XD_D12
SP12	SD_DATA4		XD_WP
SP13	SD_DATA3		XD_WEP
SP14	SD_DATA2		XD_WFE
SP15	XD_CBE		
SP16	XD_CLE		
SP17	XD_CLE		
SP18	XD_CLE		

**XD, MMC/SD, MS/MSP
5 IN1 CARD READER**

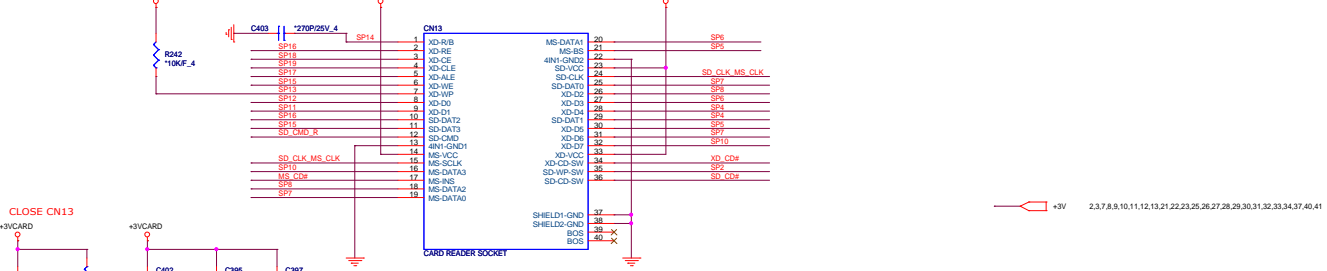

5 IN1 CARD-READER (PUSH-PUSH)
Support SD/SD PRO/MMC/MS/MS PRO/XD Cards



PROJECT : LX6_LX7
Quanta Computer Inc.

Site Custom	Document Number RTSS159 & CR SOCKET	Rev 1A
Date Tuesday, February 12, 2010	Sheet 31	of 44

2,3,7,8,9,10,11,12,13,21,22,23,24,26,27,28,29,30,31,32,33,34,37,40,41
27 +4.75VAVDD
11,21,22,23,26,28,30,31,33,34,41 +5V

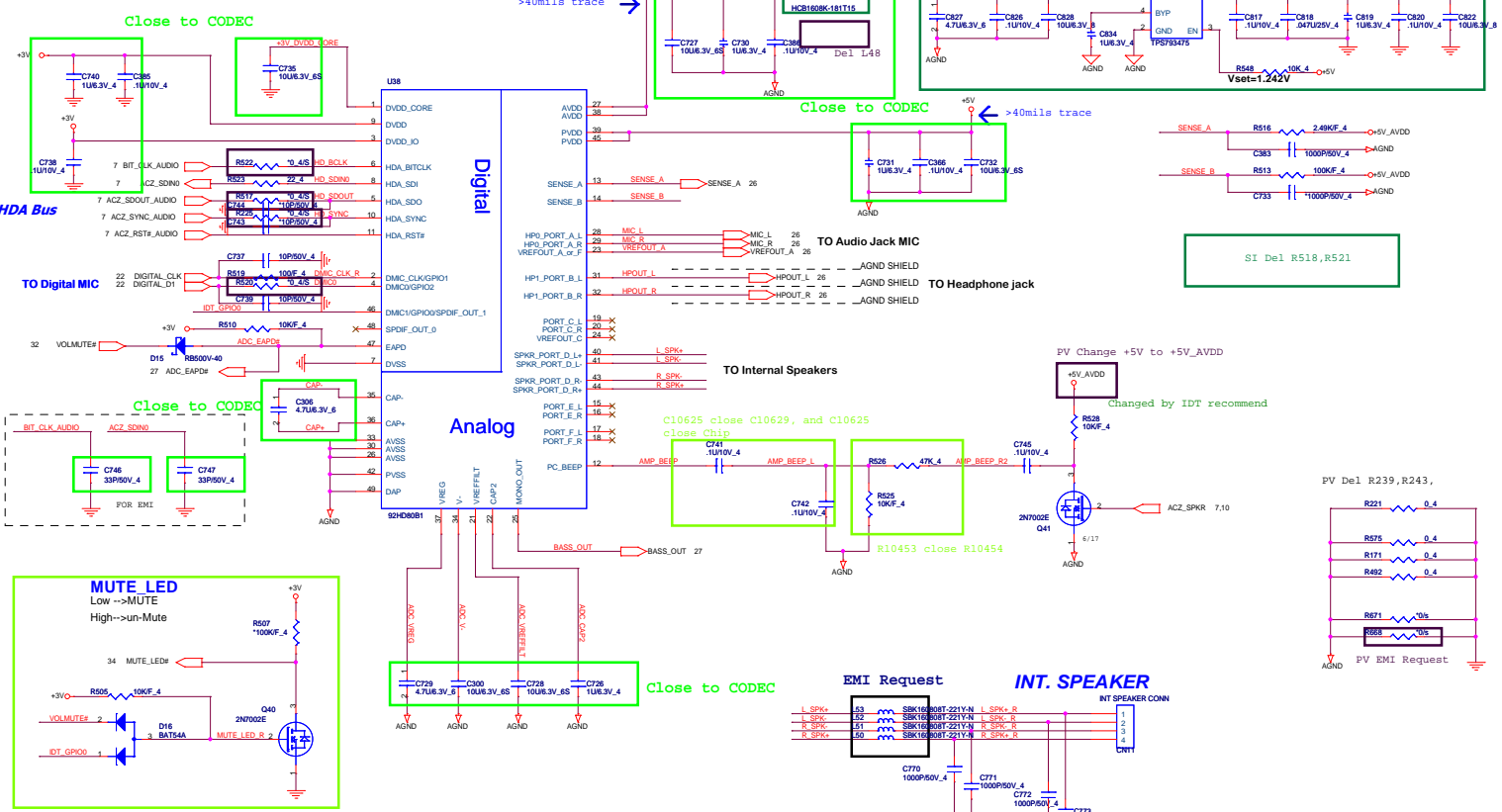

	PROJECT : LX6_LX7		
	Quanta Computer Inc.		
	Site Custom	Document Number Azaalia 02410360	Rev 2A
	Date: Tuesday, February 03, 2010	Sheet 25	of 44

Line out

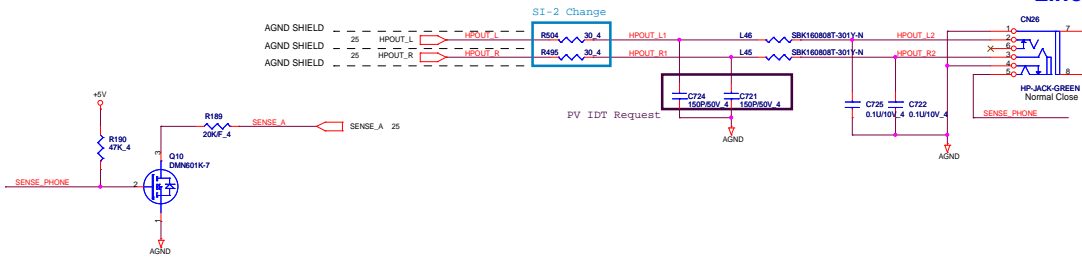

MIC

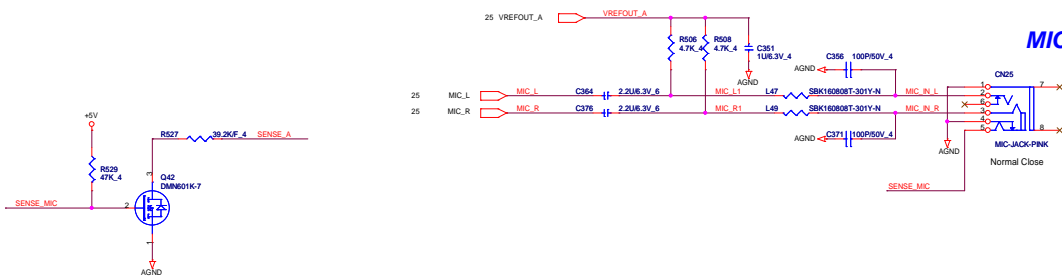

Accelerometer Sensor

SOT-LI6302DLTR interrupt pin default is low / active Hi , BIOS need to programming 22h to change status from active Hi to low

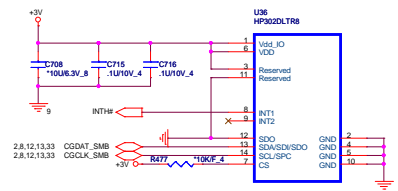

Pin 12: Low 38hex
Pin 12: unconnected/floating 3Ahex

	<p>PROJECT : LX6_LX7 Quanta Computer Inc.</p>	
	<p>Doc: Tuesday, February 13, 2010 1:58:25</p>	<p>Rev: 1A</p>

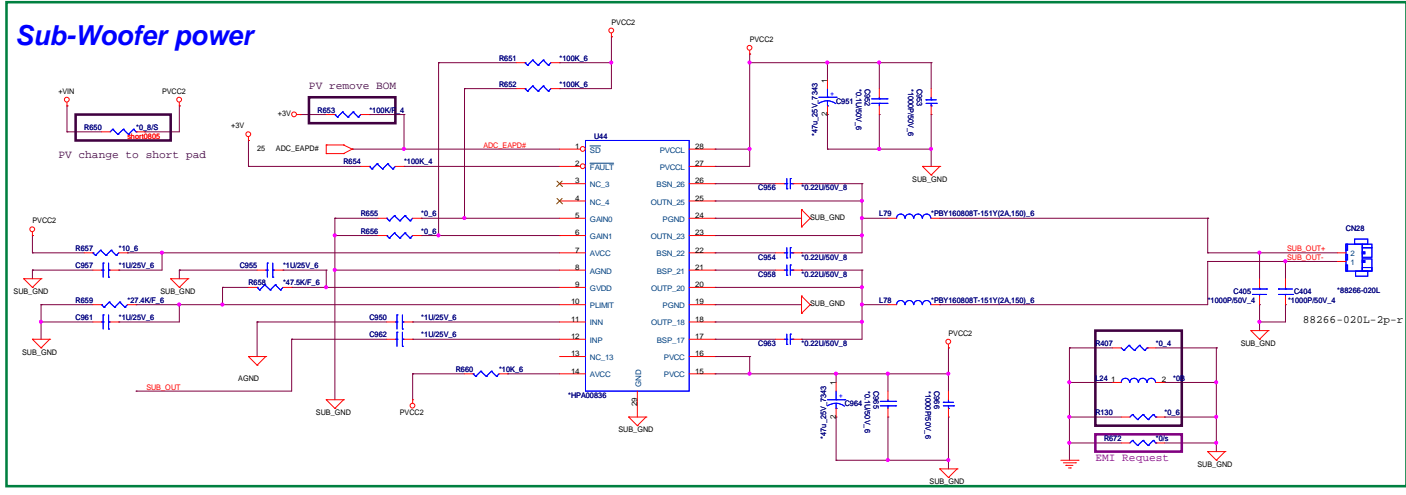
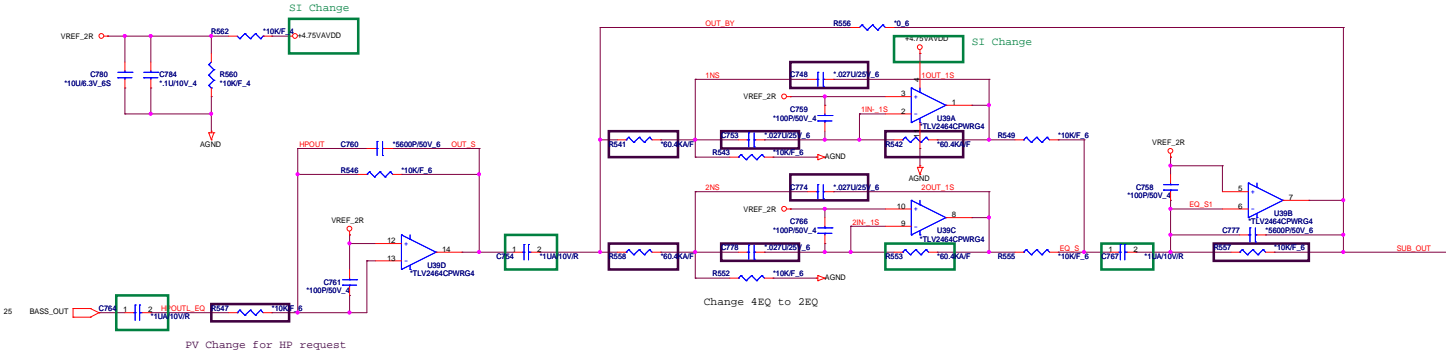

GAIN1	GAIN0	dB
0	0	1.2
0	1	1.8
1	0	23.6
1	1	36

PV Del R574, R241, R240
 R462 10B
 AGND SUB_GND

+3V 2.3, 7.8, 9.10, 11, 12, 13, 21, 22, 23, 24, 25, 26, 28, 29, 30, 31, 32, 33, 34, 37, 40, 41
 +4.75VAVDD 25 22, 35, 36, 37, 39, 40, 41, 42, 43
 +VIN

PROJECT : LX6_LX7
Quanta Computer Inc.

Site	Document Number	Rev
Custom	SUBWOOFER (EQ & AMP)	1A
Date: Tuesday, February 03, 2010	Sheet	27 of 44

BLUETOOTH

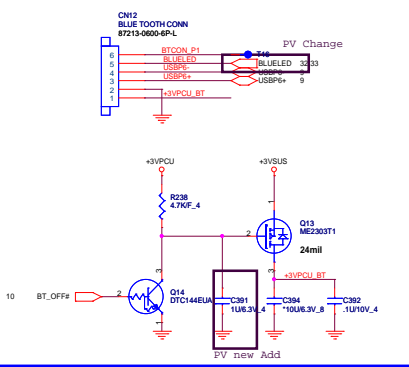

RIGHT SIDE USB2 for 17"

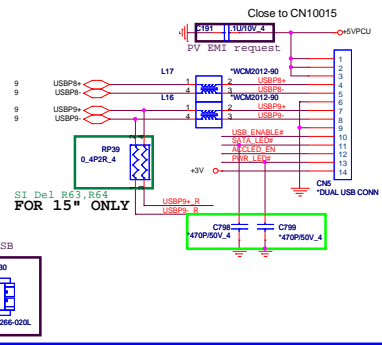

RIGHT SIDE USB for 15"

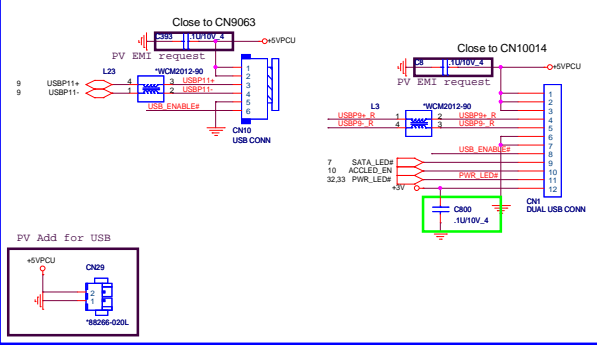

USB fingerprint CON

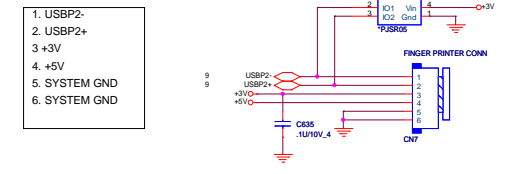

E-SATA

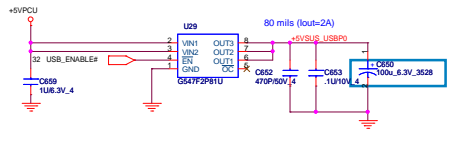

USB & ESATA

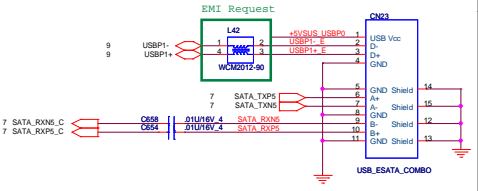

LEFT USB PORT

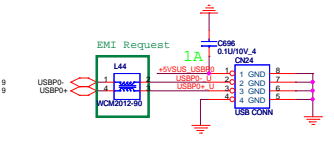

Touch screen for 15"

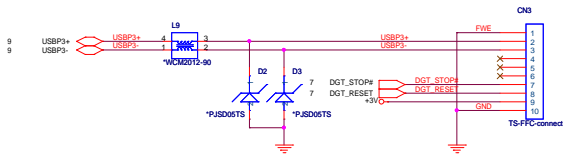

PROJECT : LX6_LX7
Quanta Computer Inc.

Site: Custom	Document Number: BT/WO/FIT/Touchscreen	Rev: 1A
Date: Tuesday, February 03, 2010	Sheet: 28	of 44

T: Stuffed for RTL8111DL(10/100/1000)

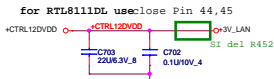

Remove R3571,R3573
 R3571 and R3573 are used in RTL8111DL, remove R3573 if switching regulator is enable, Remove R3571 external power is used.

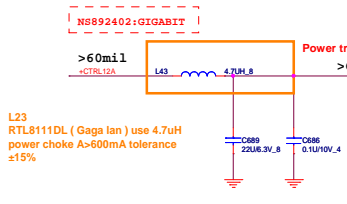
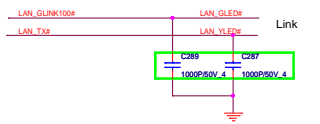
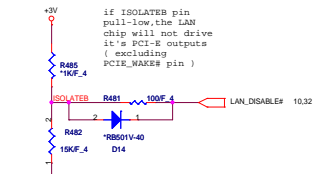
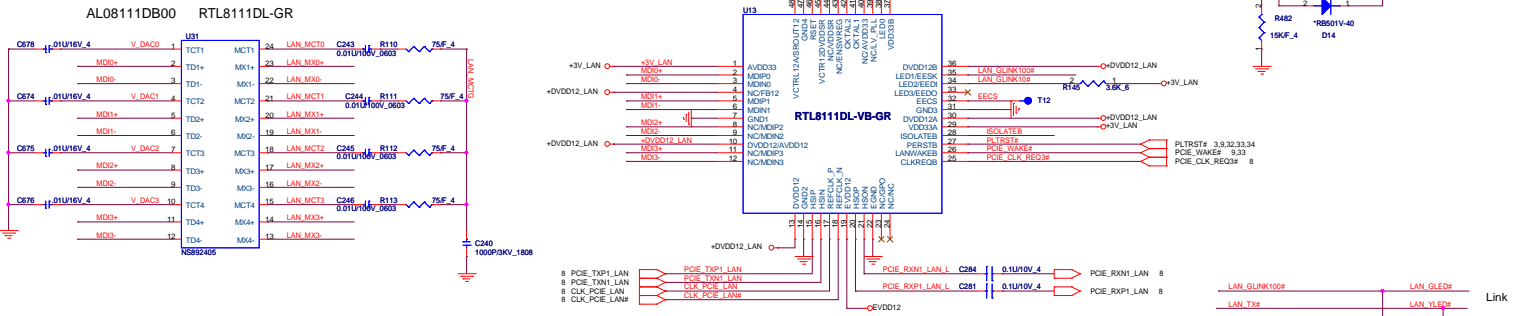
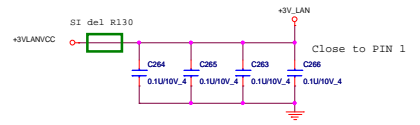

L23
 RTL8111DL (Giga lan) use 4.7uH power choke A>600mA tolerance ±15%

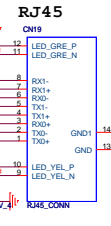
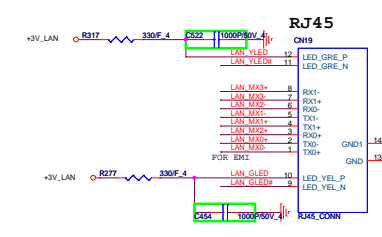
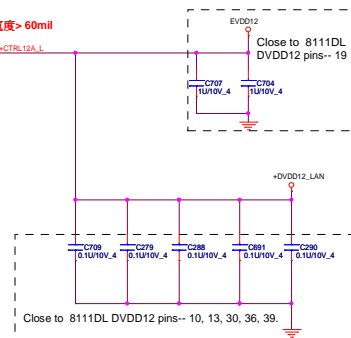

	PROJECT : LX6_LX7		Quanta Computer Inc.	
	Spec	Document Number		Rev
	Custom	8103ERJ445		1A
	Date: Tuesday, February 03, 2010	Sheet	26	of 44

SATA HDD CONNECTOR

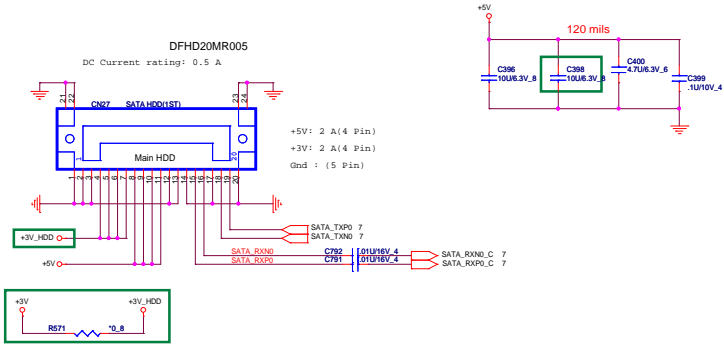

SATA CD-ROM

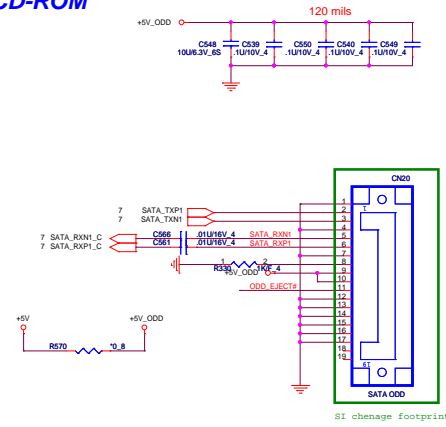

SATA_2 CONNECTOR FOR 17.3"

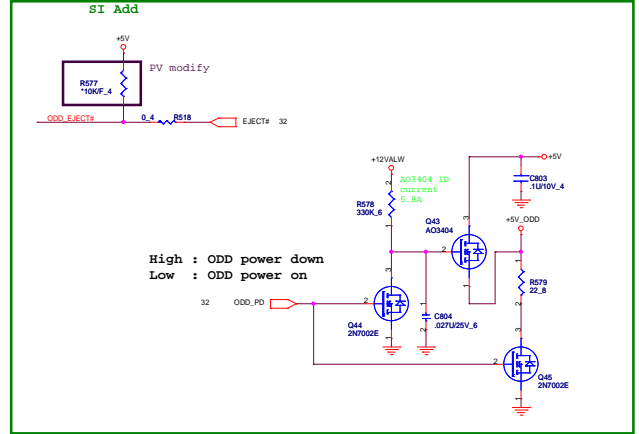
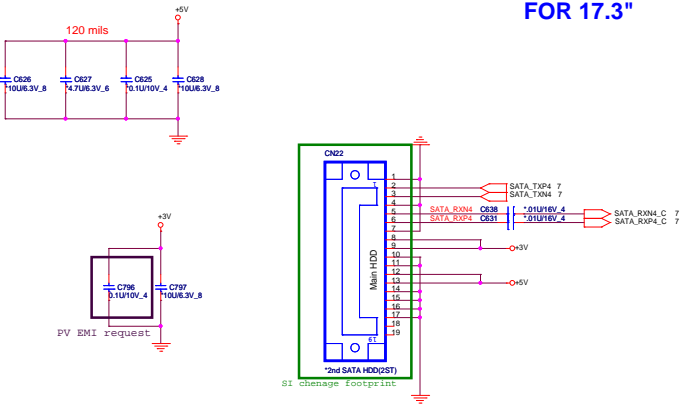

- ≡ +3V 2,3,7,8,9,10,11,12,13,21,22,23,24,25,26,27,28,29,31,32,33,34,37,40,41
- ≡ +5V 11,21,22,23,25,26,28,31,33,34,41
- ≡ +12VALLW 22,34,39,41

	PROJECT : LX6_LX7 Quanta Computer Inc.		Rev 1A
	SPC Custom	Document Number ODD/HDD/ANT	

For UMA HDMI function for UMA

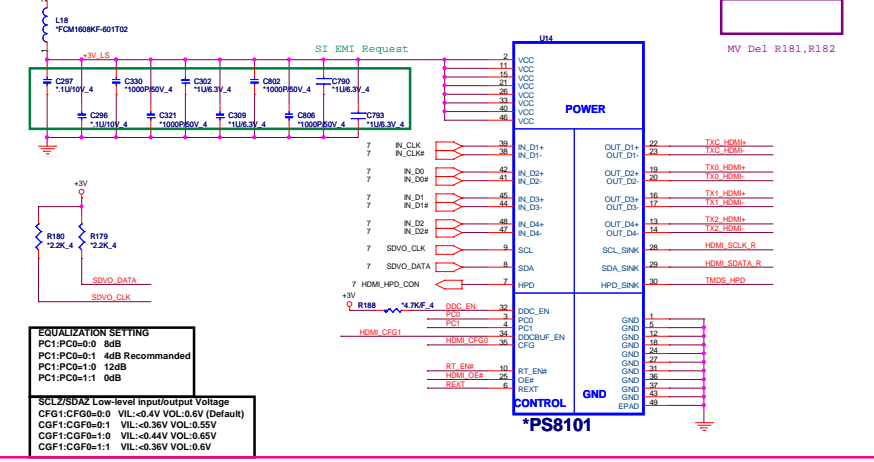

for UMA Close to HDMI(CN21) Connector

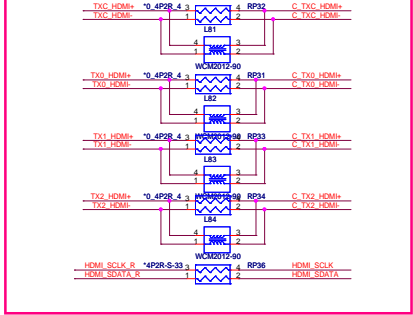

for SG/DIS Close to HDMI(CN21) Connector

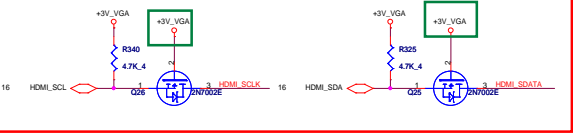

Signals		PDT	CHR	PIM
PCI	Ra	NC	4.7K	NC
HDMI_CFG0	Rb	NC	NC	NC
HDMI_CFG1	Rc	4.7K	NC	NC
REXT	Rd	499	1.2K	4.7K
PCL	Re	NC	NC	4.7K
HDMI_OE#	Rf	NC	4.7K	NC
PC0	Rg	4.7K	4.7K	4.7K

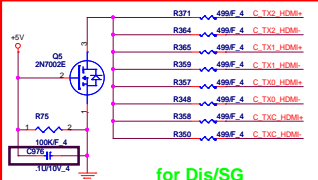

Vendor:PDT P/N:AL008101000
 Vendor:CHR P/N:AL007318002
 Vendor:PIM P/N:ALP411LS004

R185	Rg	4.7K	PC0	R186	4.7K
R186	Ra	4.7K	PCI	R187	4.7K
R187	Rb	4.7K	HDMI_CFG0	R188	4.7K
R188	Rc	4.7K	HDMI_CFG1	R189	4.7K

Rd
 REXT R178 499F 4
 RT_EN# R178 10K 4
 HDMI_OE# R178 4.7K 4

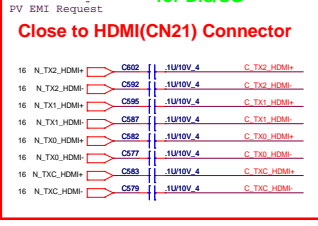

SI Del Q29,R378,R413,R415

MV Del R670,R669

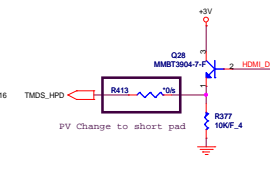

PV Change to short pad

PV Del R374,R368,R378 BOM

for UMA/DIS/SG

+5V	11,21,22,23,25,26,28,30,33,34,41
+3V	2,3,7,8,9,10,11,12,13,21,22,23,24,25,26,27,28,29,30,32,33,34,37,40,41
+3V_VGA	15,16,17,18,34,39

PROJECT : LX6_LX7
Quanta Computer Inc.

See Custom Document Number
KB5-POWER CONN

Date: Tuesday, February 22, 2010 1 Sheet 31 of 44

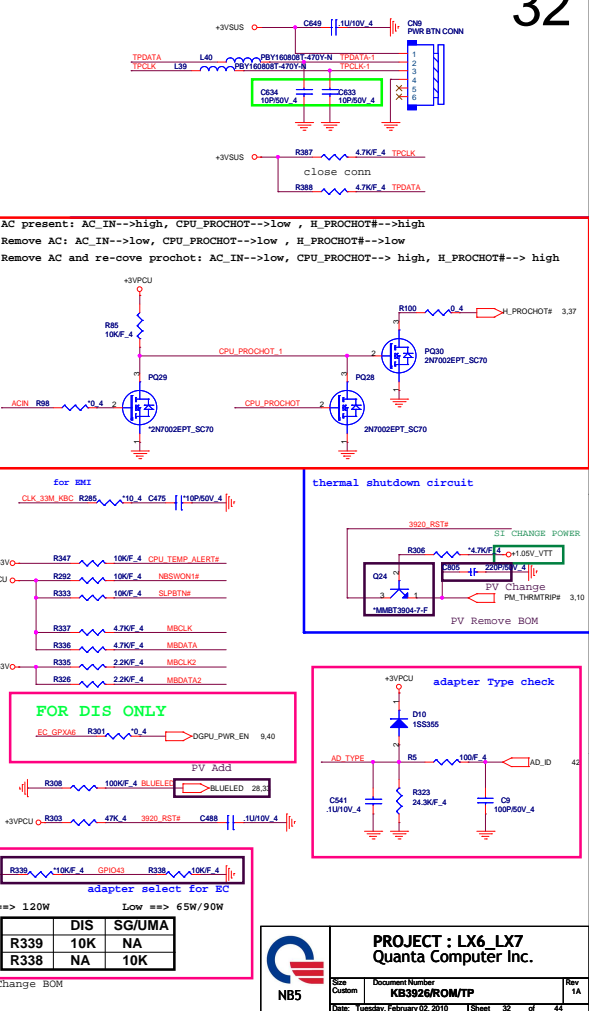
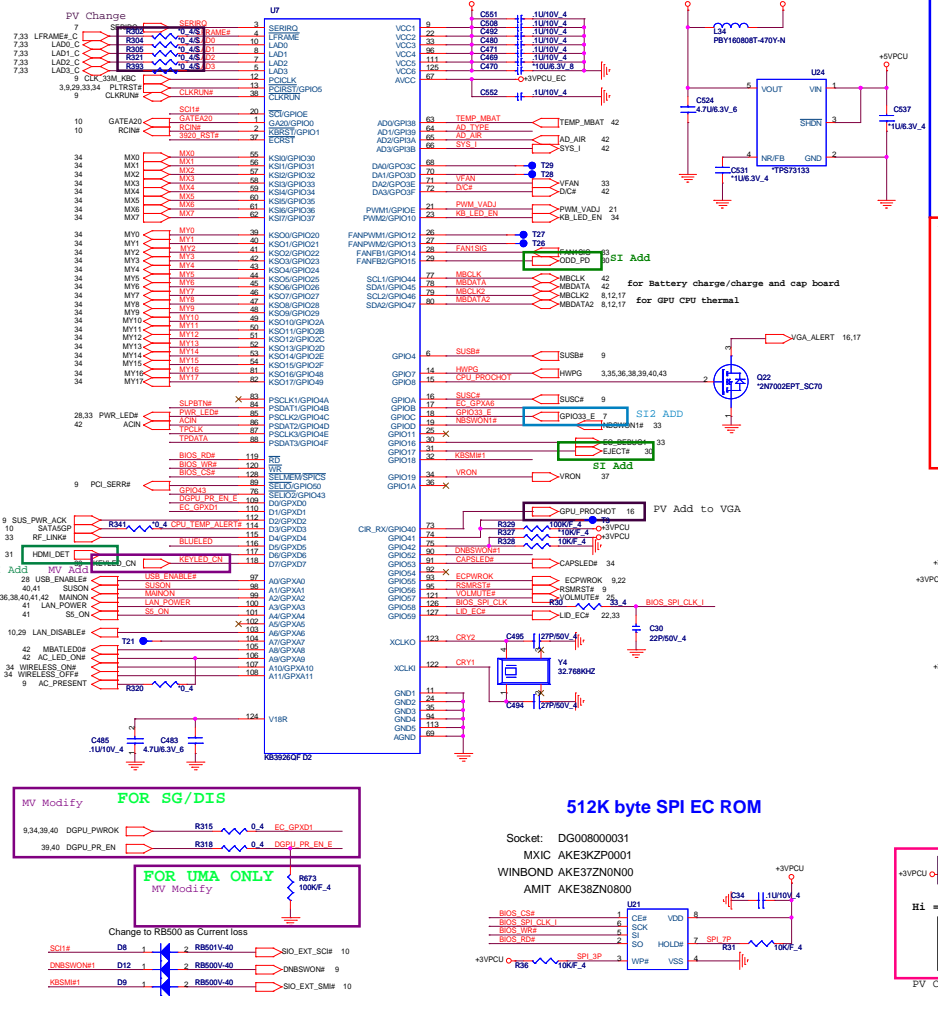

FOR SG/DIS
 MV Modify
 9.34.39.40 DGPU_PWROK R315 0.4 EC_GPXD1
 39.40 DGPU_PR_EN R316 0.4 DGPU_PR_EN_E

FOR UMA ONLY
 MV Modify
 R317 100K 4

Change to RB500 as Current loss
 RBS50V-40

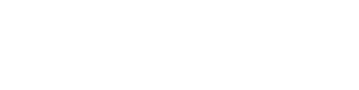

512K byte SPI EC ROM

Socket: DGO8000031
 MXIC AKE3KZP0001
 WINBOND AKE37ZN000
 AMIT AKE38ZN0800

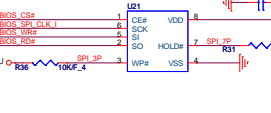

adapter select for EC

Hi ==>	I20W	DIS	SG/UMA
Low ==>	65W/90W	R339	10K
		R338	NA 10K

PV Change BOM

PROJECT : LX6_LX7
 Quanta Computer Inc.

Sec	Docu	Number	Rev
NB5	Custom	KB3226/ROM/TTP	1A
Date:	Monday, February 13, 2010	1	Sheet 32 of 44

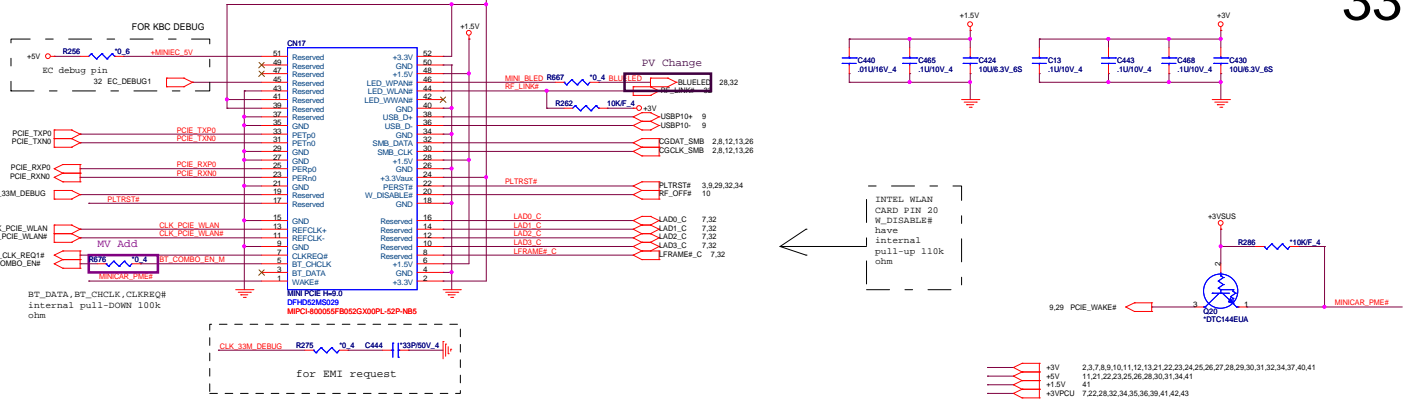

CPU FAN

POWER BUTTON CONNECT

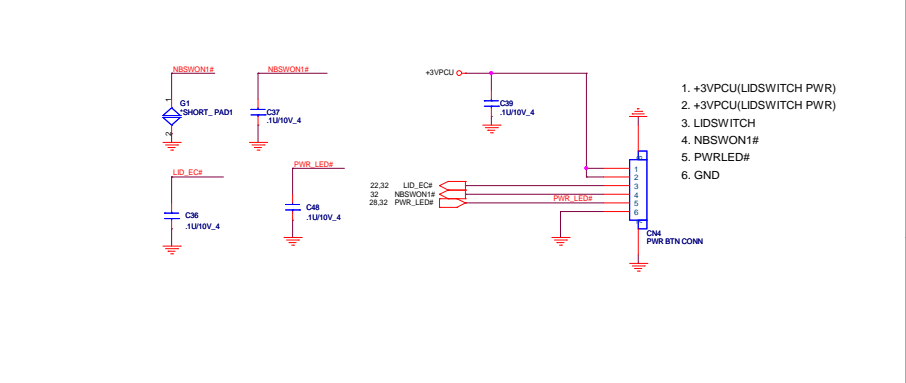
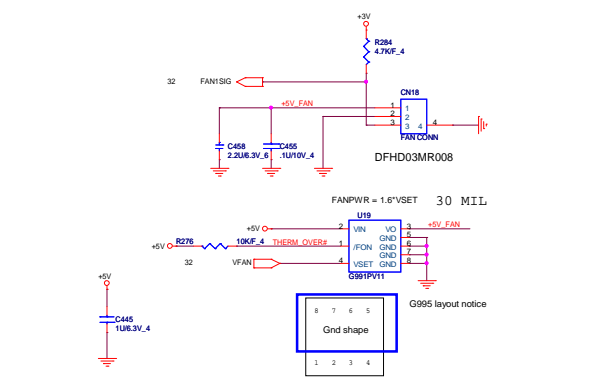

		PROJECT : LX6_LX7 Quanta Computer Inc.	
Ssn Custom	Document Number MINI PCI-E CONN/FAN	Rev 1A	Date Tuesday, February 13, 2010 1 Sheet 33 of 44

KEYBOARD PULL-UP

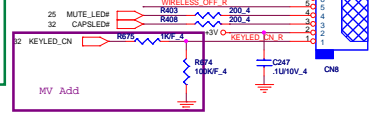
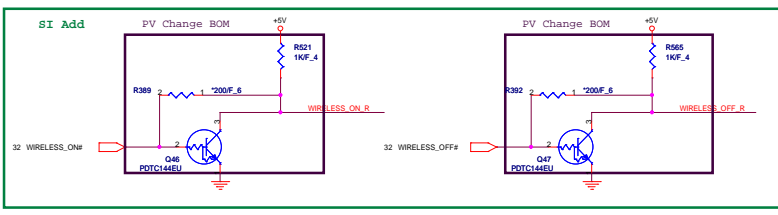
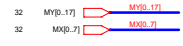
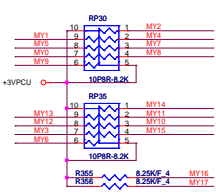

clear ABS 758 resin for key cap.
7 LEDs for 15.4" (total LED current 140mA)
11 LEDs for 17" (Total LED current 220mA)

KB backlight for 15"

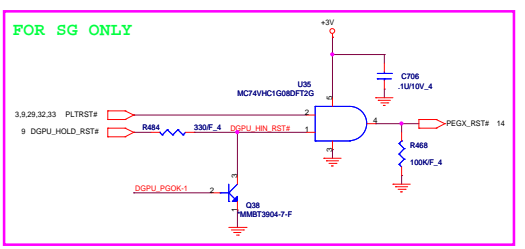
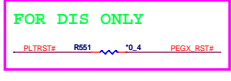
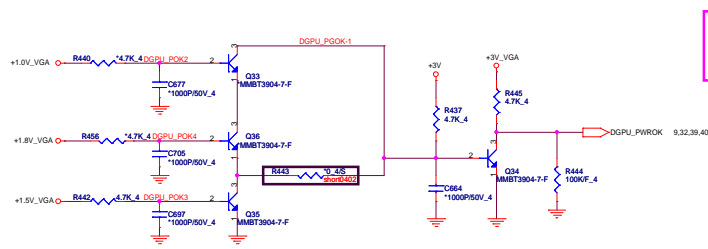
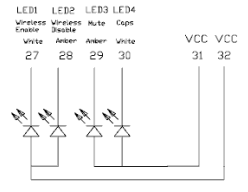
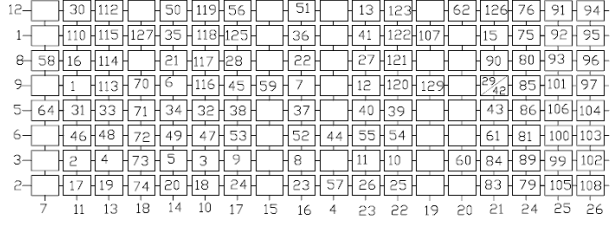
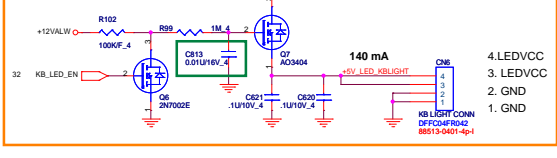

+3V	2,3,7,8,9,10,11,12,13,21,22,23,24,25,26,27,28,29,30,31,32,33,37,40,41
+5V	11,21,22,23,25,26,28,30,31,33,41
+3VPCU	7,22,28,32,33,35,36,39,41,42,43
+5V_VGA	15,16,17,18,31,39
+12V_ALW	22,30,39,41
+1.0V_VGA	14,16,18,40
+1.5V_VGA	15,18,19,20,39
+1.8V_VGA	14,16,18,39

PROJECT : LX6_LX7	
Quanta Computer Inc.	
Rev	1A
Doc#	February 02, 2010
Sheet	34 of 44

+5V +/- 5%
 Countinue current:6A
 Peak current :8A
 OCP minimum :10A

+3.3V +/- 5%
 Countinue current:5A
 Peak current:6A
 OCP minimum 7.5A

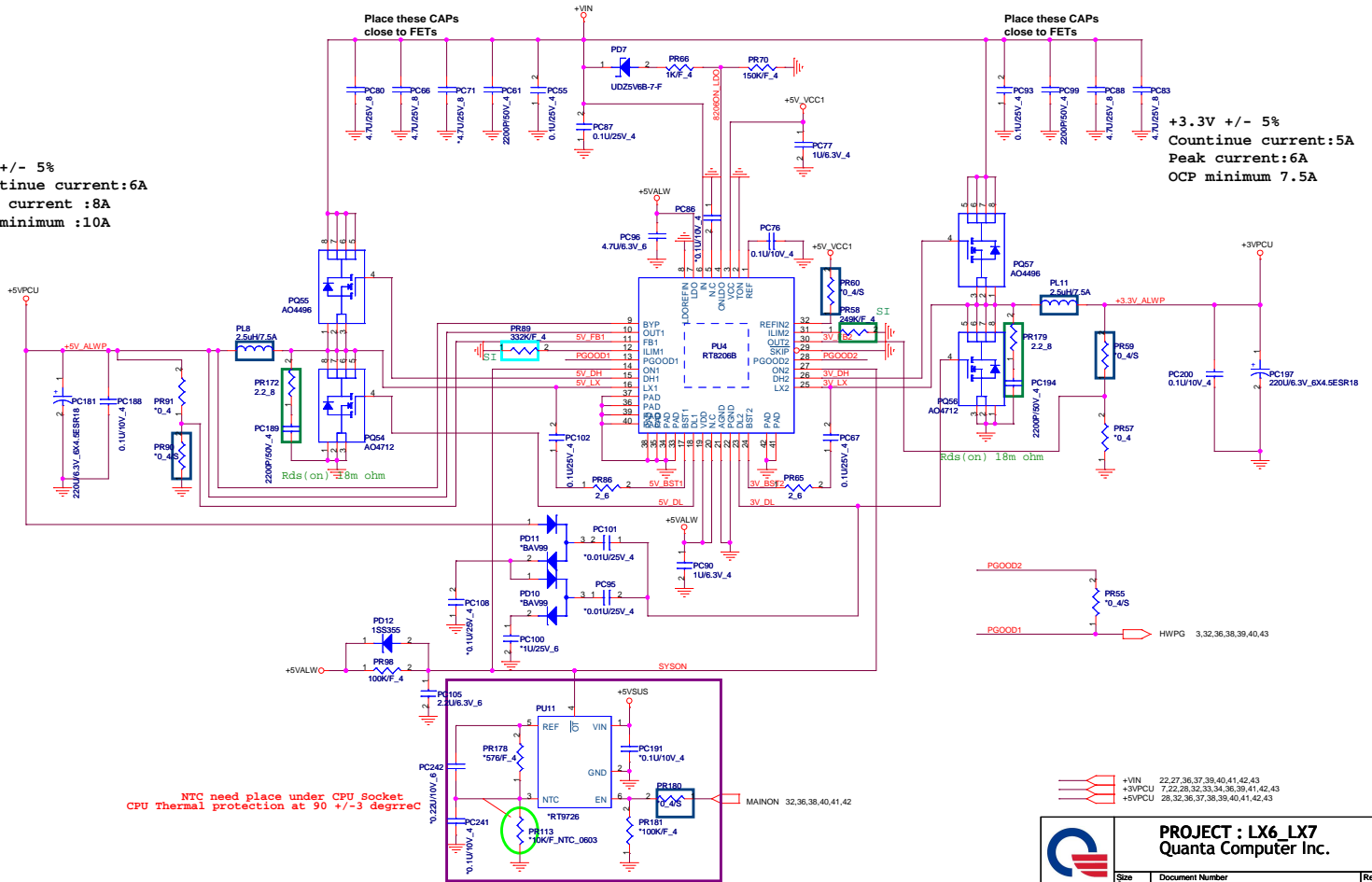

- +VIN 22,27,36,37,38,40,41,42,43
- +3VPCU 7,22,26,32,33,34,36,38,41,42,43
- +5VPCU 28,32,36,37,38,39,40,41,42,43

PROJECT : LX6_LX7
Quanta Computer Inc.

Size Custom	Document Number +5V/+3V (RT8206B)	Rev 1A
Date: Tuesday, February 02, 2010 Sheet 35 of 44		

NTC need place under CPU Socket
 CPU Thermal protection at 90 +/-3 degreeC

MV Change

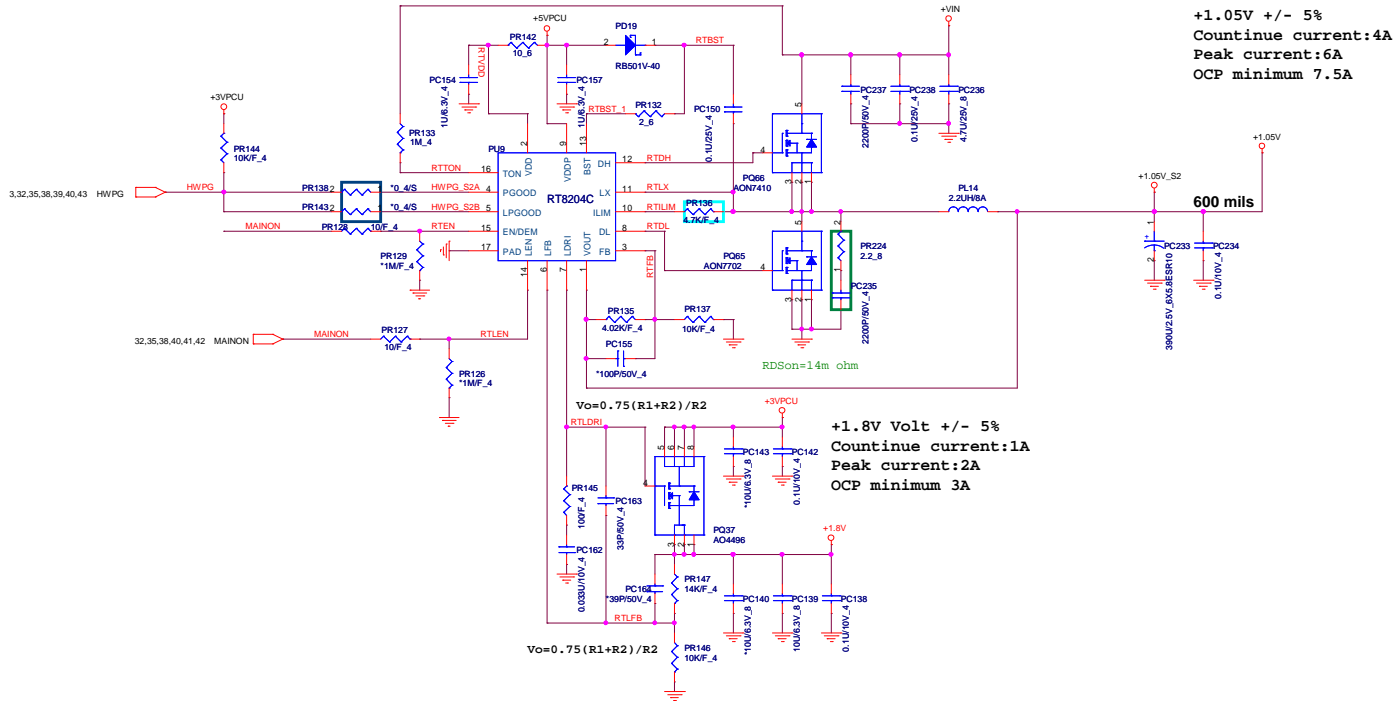

+1.05V +/- 5%
Countinue current:4A
Peak current:6A
OCP minimum 7.5A

+1.8V Volt +/- 5%
Countinue current:1A
Peak current:2A
OCP minimum 3A

$$V_o = 0.75(R1+R2) / R2$$

$$V_o = 0.75(R1+R2) / R2$$

- +1.8V 5,10,11,21,41
- +VIN 22,27,35,37,39,40,41,42,43
- +1.05V 2,7,8,9,11,37,43
- +3VPCU 7,22,28,32,33,34,35,39,41,42,43
- +5VPCU 28,32,35,37,39,39,40,41,42,43

	PROJECT : LX6_LX7 Quanta Computer Inc.		Rev 1A
	Size Custom	Document Number +1.05V/+1.8V (RT8204C)	

	DIS (Clarksfield)	SG/UMA (Arburndle)
不上件	PQ45 PQ46 PQ43 PQ44	
PR14	1.91k(OCP=63A) (CS21912FB13)	1.69k(OCP=55A) (CS21692FB01)
PR34	4.7k (CS24702FB10)	4.87k (CS24872FB07)

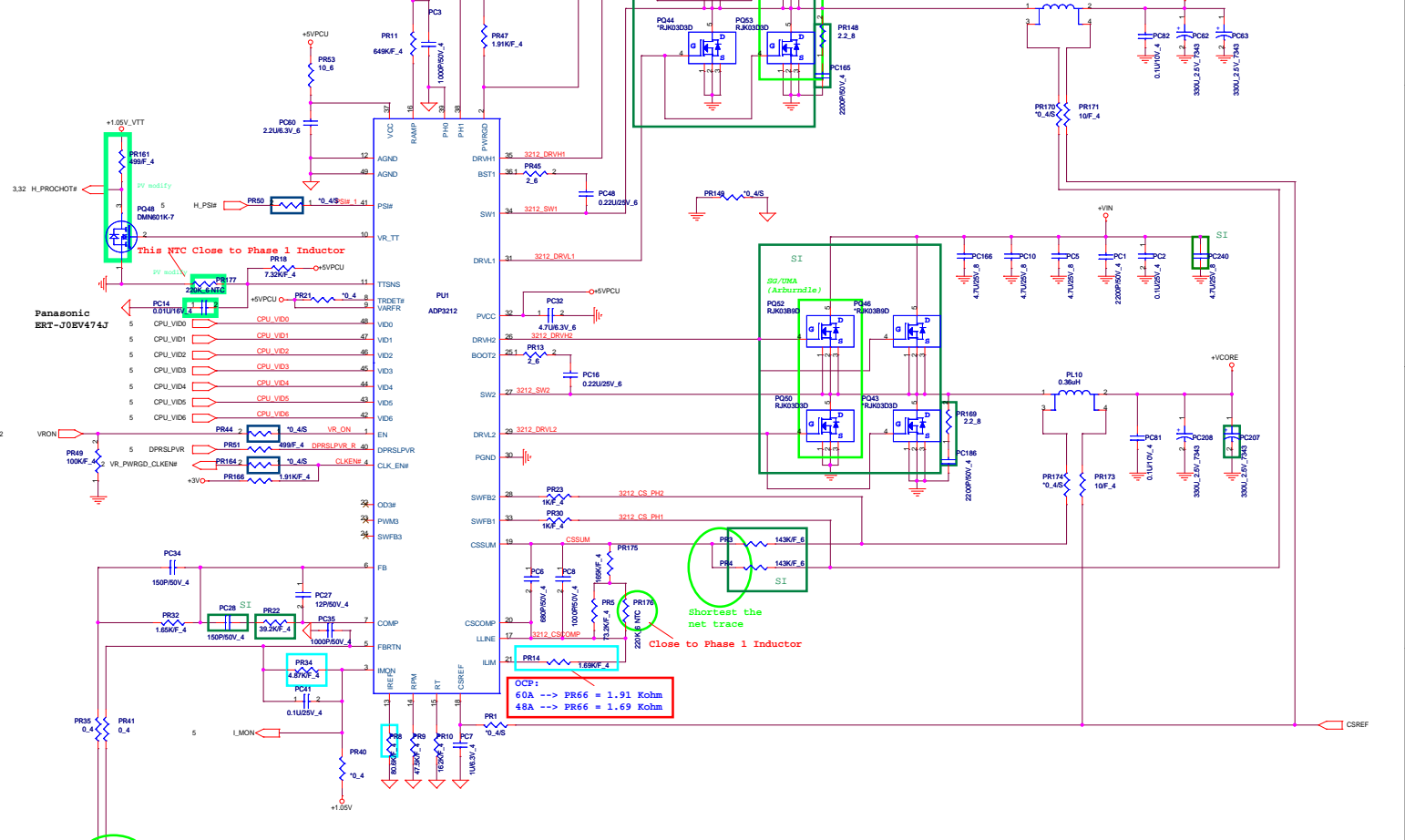

+VCCORE
 Countinue current:24A
 Peak current:40A
 OCP minimum 48A

	PROJECT : LX6_LX7 Quanta Computer Inc.	Rev 1A
	Document Number CPU Core (ADP3212)	Rev 1A
Date: Tuesday, February 02, 2010 13:58	Sheet 37 of 44	

	SG	DIS	UMA
PR156 PR26 PR29 PQ8	Stuff	Stuff	no Stuff
PR157	40.2K (CS34022FB15)	40.2K (CS34022FB15)	38.3K (CS33832FB08)

	Clarksfild	Arraindle
PU10	VT358 (AL000358U00)	VT357 (AL000357U00)
PR160	40.2K (CS34022FB15)	36K (CS33602FB15)
PR158	5.76K (CS25762FB01)	6.49K (CS26492FB23)

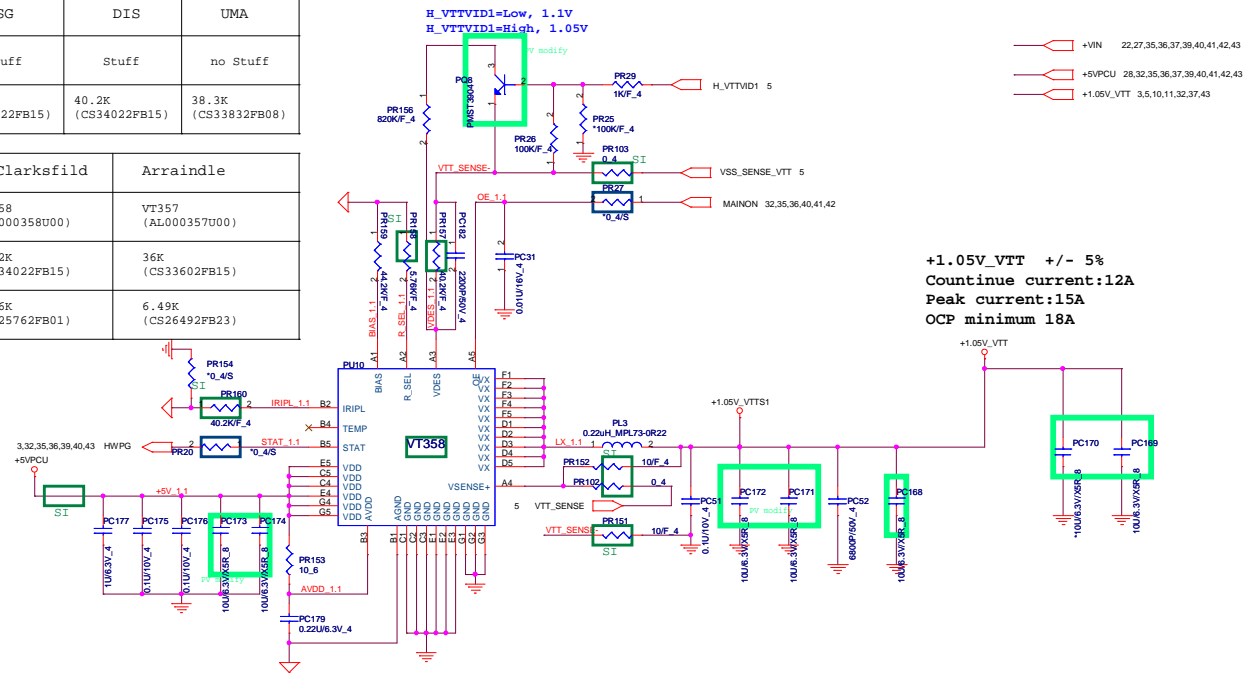

+1.05V_VTT +/- 5%
Countinue current:12A
Peak current:15A
OCP minimum 18A

	PROJECT : LX6_LX7		Rev 1A
	Quanta Computer Inc.		
	Size Custom	Document Number +1.05V_VTT (VT358)	
Date: Tuesday, February 02, 2010		Sheet 38 of 44	

VGA Core

+VGACORE +/- 5%
 Countinue current:19A
 Peak current:21A
 OCP minimum 26A

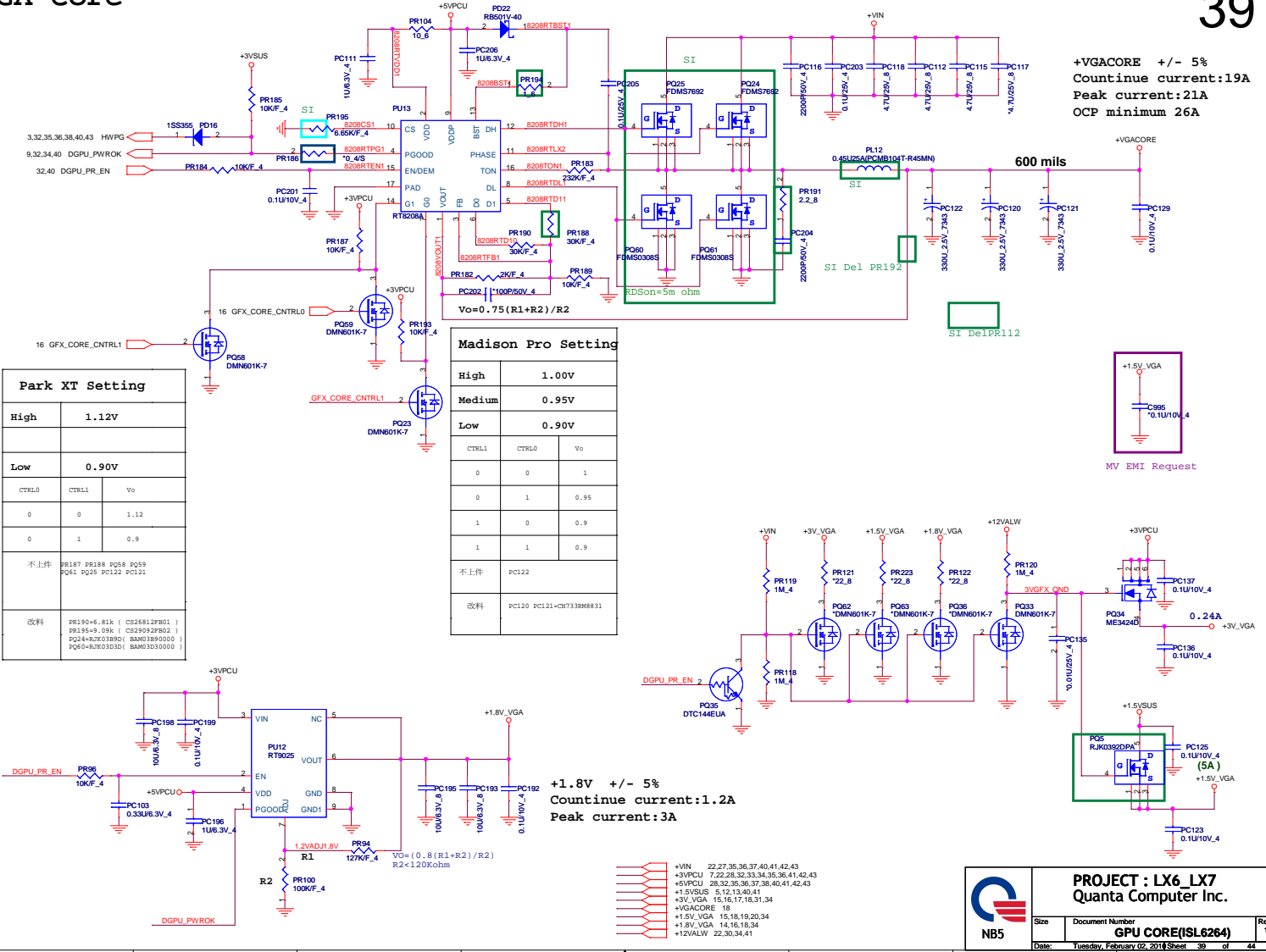

Park XT Setting

High	1.12V	
Low	0.90V	
CTRL0	CTRL1	Vo
0	0	1.12
0	1	0.9
不上件	PR187 PR188 PQ58 PQ59 PQ61 PQ25 PC122 PC121	
改料	PR190=4.81k (CS26812F801) PR191=9.09k (CS29092F802) PQ24=820338D (BA603890000) PQ60=820338D (BA603890000)	

Madison Pro Setting

High	1.00V	
Medium	0.95V	
Low	0.90V	
CTRL1	CTRL0	Vo
0	0	1
0	1	0.95
1	0	0.9
1	1	0.9
不上件	PC122	
改料	PC120 PC121=CH733R8831	

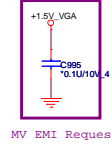

MV EMI Request

+1.8V +/- 5%
 Countinue current:1.2A
 Peak current:3A

- +VIN 22,27,35,36,37,40,41,42,43
- +3VPCU 7,22,28,32,33,34,35,36,41,42,43
- +5VPCU 26,32,35,36,37,38,40,41,42,43
- +1.5V_VGA 5,12,13,40,41
- +3V_VGA 15,16,17,18,31,34
- +VGACORE 18
- +1.5V_VGA 15,18,19,20,34
- +1.8V_VGA 14,16,18,34
- +12VALW 22,30,34,41

PROJECT : LX6_LX7
 Quanta Computer Inc.

Size	Document Number	Rev
	GPU CORE(ISL6264)	1A
Date:	Tuesday, February 02, 2011	Sheet 39 of 44

+1.5V +/- 5%
 Countine current:6A
 Peak current:12A
 OCP minimum 15A

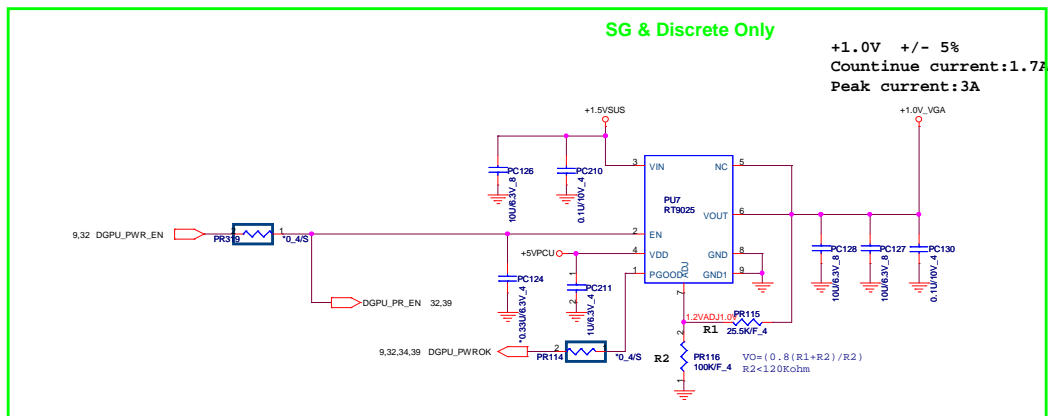
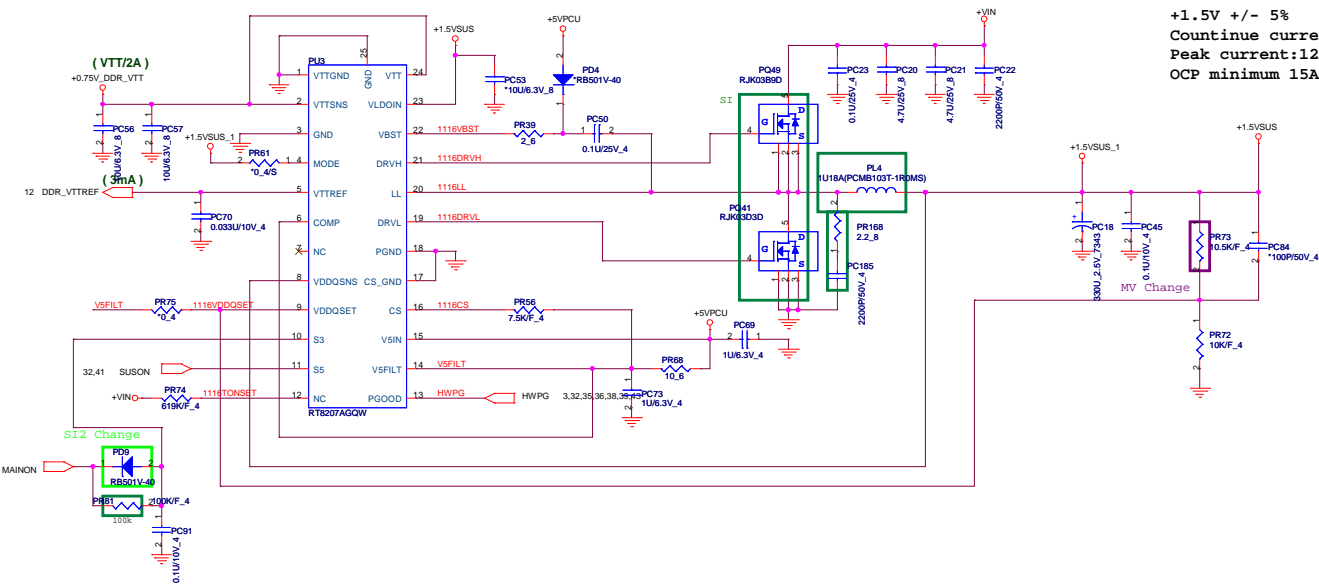

+1.0V +/- 5%
 Countine current:1.7A
 Peak current:3A

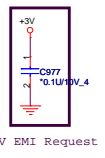

PV EMI Request

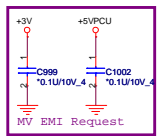

MV EMI Request

- +3V 2,3,7,8,9,10,11,12,13,21,22,23,24,25,26,27,28,29,30,31,32,33,34,37,41
- +VIN 22,27,35,36,37,39,41,42,43
- +5VPCU 28,32,35,36,37,39,39,41,42,43
- +1.5VSUS 5,12,13,39,41
- +1.0V_VGA 14,16,18,34
- +0.75V_DDR_VTT 12,13,41

	PROJECT : LX6_LX7 Quanta Computer Inc.		Rev 1A
	Size Custom	Document Number DDR3 (RT8207)	

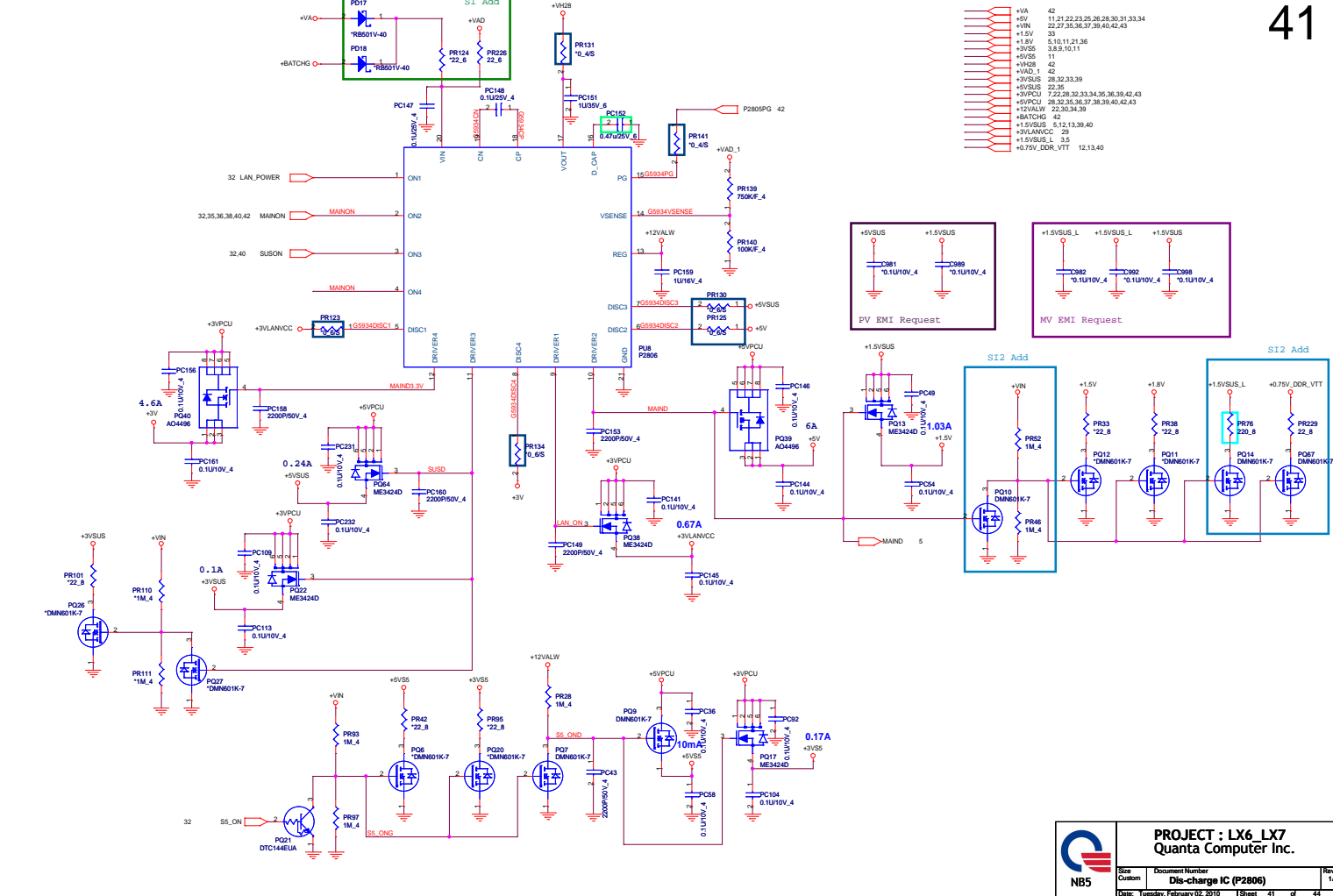

+VA	42
+5V	11,21,22,23,25,26,28,30,31,33,34
+VIN	22,27,35,36,37,39,40,42,43
+1.5V	33
+1.8V	5,10,11,21,36
+5VSS	3,8,9,10,11
+5VSS	11
+VHS	42
+VAD_1	42
+5VSS	28,32,33,39
+5VSS	22,35
+5VPU	7,25,28,30,33,34,35,36,39,42,43
+12VALW	22,30,34,39
+2VLANVCC	29
+1.5VSS_L	5,12,13,39,40
+5VSS_L	29
+0.75V_DDR_VTT	12,13,40

	PROJECT : LX6_LX7
	Quanta Computer Inc.
	Doc: Tuesday, February 13, 2010 Sheet 41 of 44

Site Custom	Document Number	Rev
	Dis-charge IC (P2806)	1A

Do Not add test pad on BATDIS_G signal

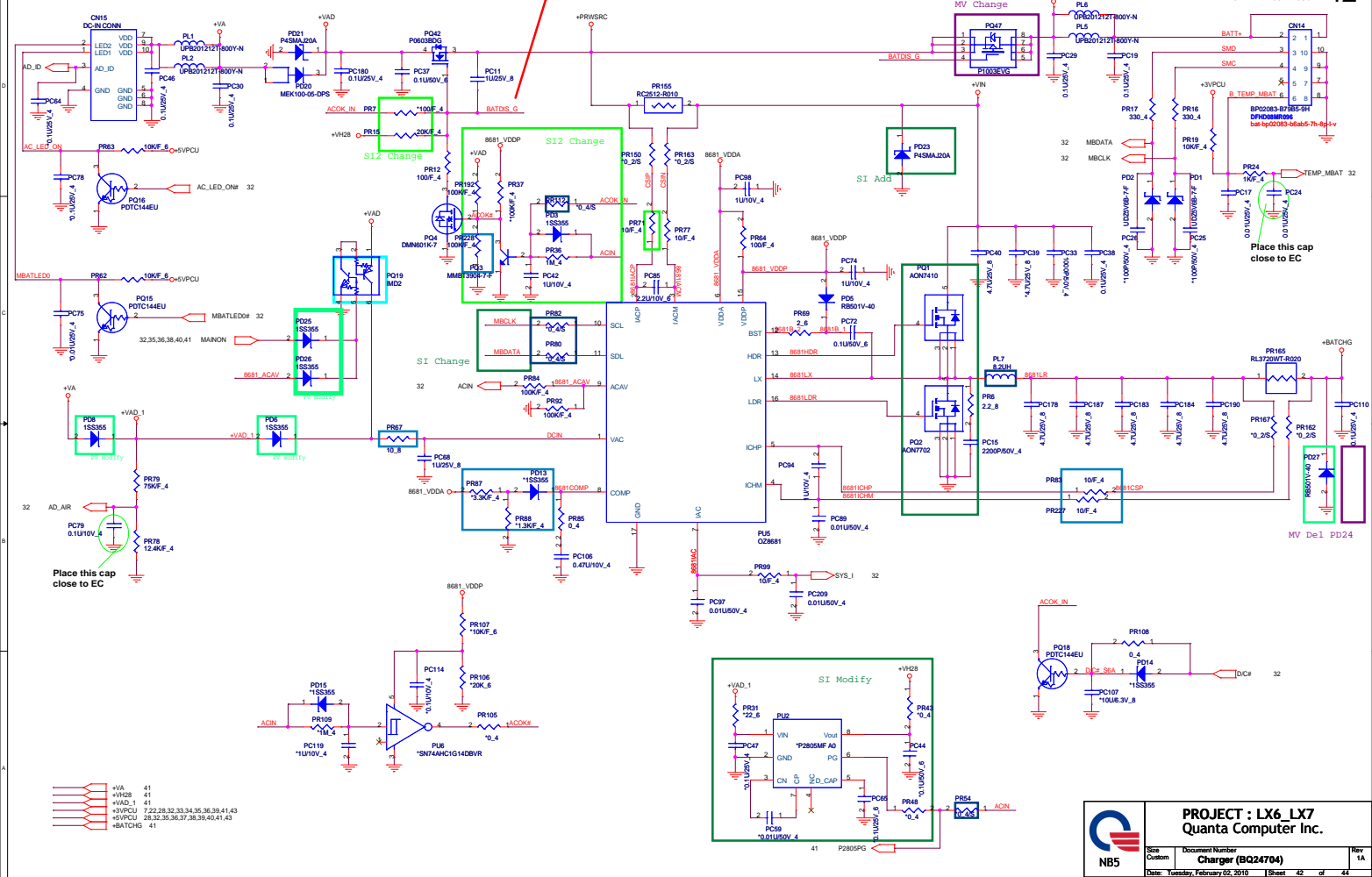

	PROJECT : LX6 LX7		Rev 1A
	Quanta Computer Inc.		
	Size: Custom Document Number: Charger (BQ24704) Date: Tuesday, February 05, 2010 15:28:42	Sheet 42 of 44	

+VGACORE_IGPU	5
+VIN	22,27,35,36,37,39,40,41,42
+5VPCU	28,32,35,36,37,39,39,40,41,42
+1.05V	2,7,8,8,11,36,37
+3VPCU	7,22,28,32,33,34,35,36,39,41,42
+1.05V_VTT	5,5,10,11,32,37,38

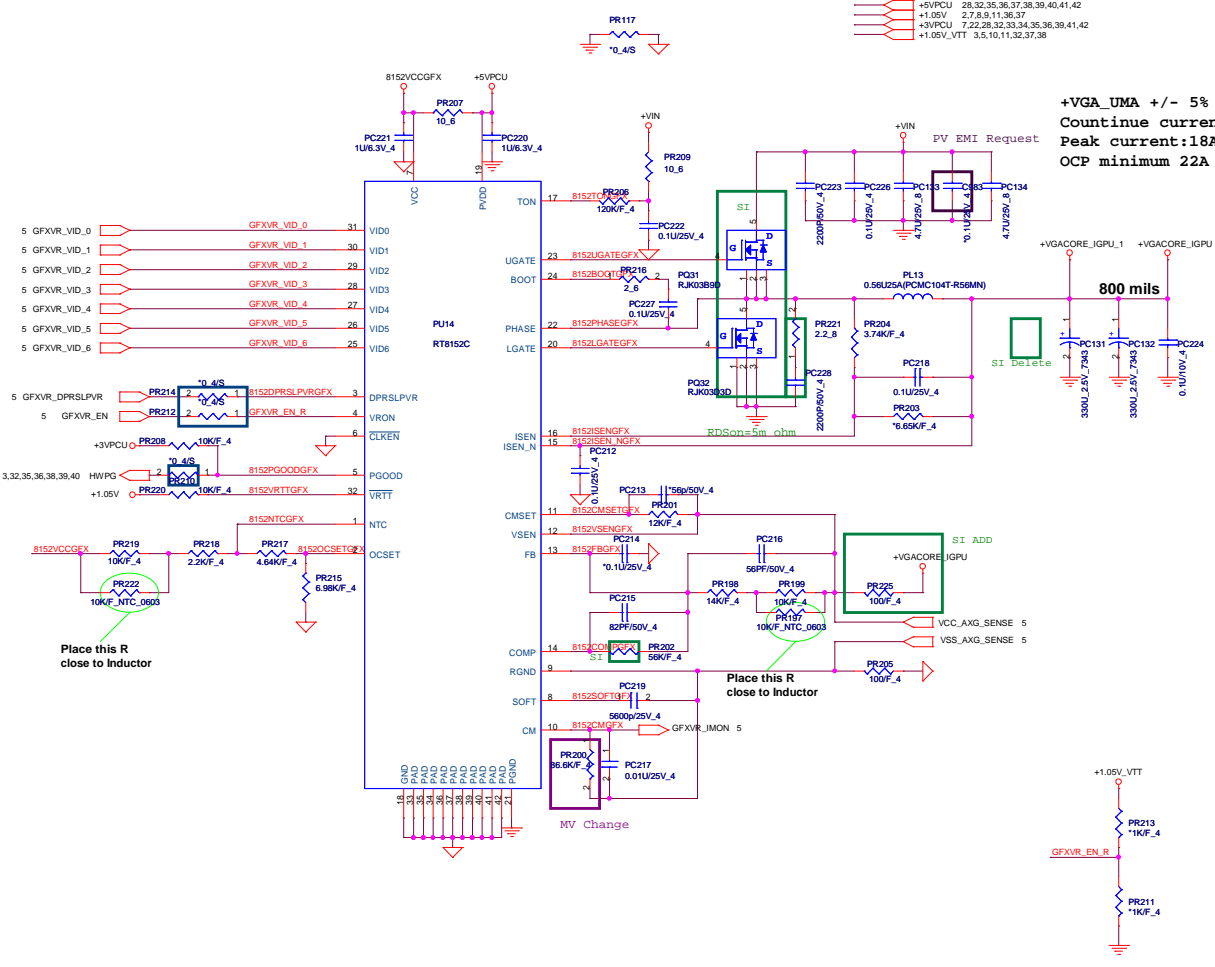

+VGA_UMA +/- 5%
 Countinue current:12A
 Peak current:18A
 OCP minimum 22A

800 mils

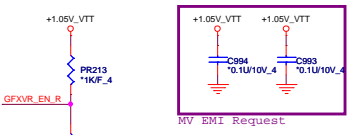

	PROJECT : LX6_LX7 Quanta Computer Inc.		Rev 1A
	Size Custom	Document Number UMA GPU CORE (RT8152C)	

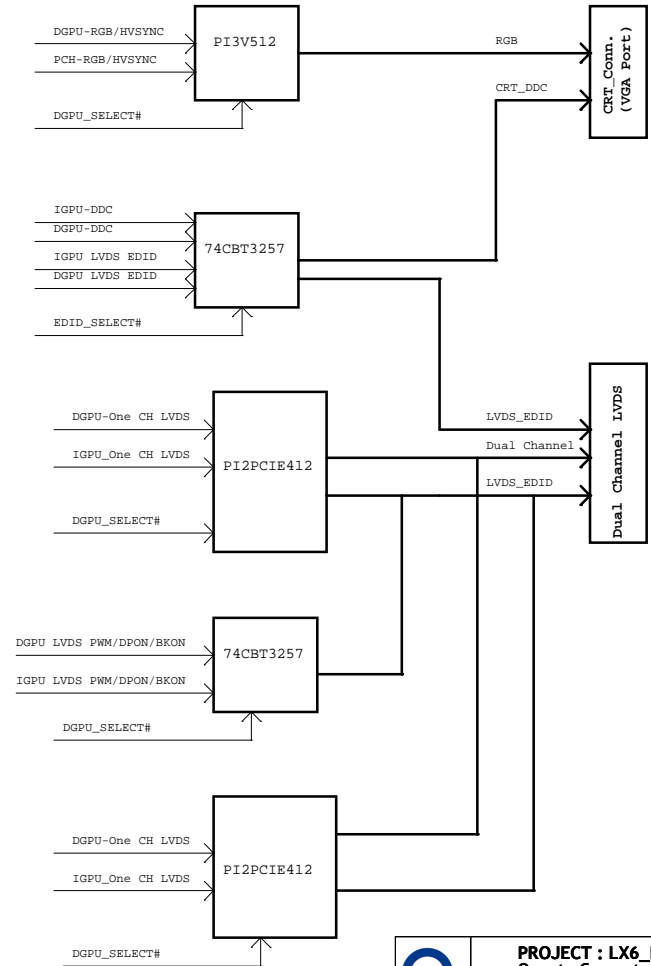
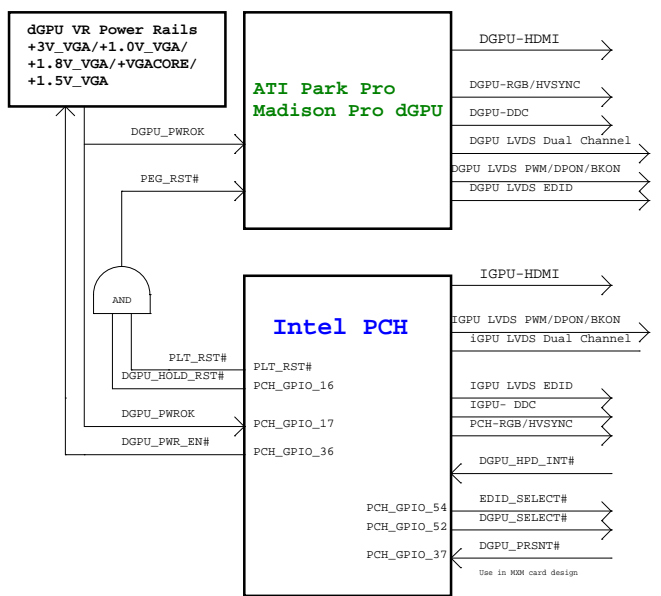

Switchable GPIOs	Descriptions
PCH_GPIO52	DGPU_SELECT#
PCH_GPIO16	DGPU_HOLD_RST#
PCH_GPIO36	DGPU_PWR_EN#
PCH_GPIO17	DGPU_PWR_OK
PCH_GPIO54	EDID_ELECT#
PCH_GPIO37	DGPU_PRSENT#

PROJECT : LX6 LX7
Quanta Computer Inc.

Size Custom	Document Number Switch Blockdiagram	Rev 1A
Date: Tuesday, February 02, 2010	Sheet	44 of 44

www.s-manuals.com